

TOLY-KOREA

SKINCARE & MAKE UP PACKAGING

TOLY-KOREA

SKINCARE & MAKE UP PACKAGING



Korea 2021

TOLY-KOREA

Passionate About Packaging
www.toly.com | www.tolykorea.com

TOLY-KOREA

TOLY, The Best Provider of Cosmetics Packaging

Toly Products Ltd, founded in 1971,
is now one of the world's leading luxury packaging manufacturers in the cosmetic,
fragrance and skin care industries.

Toly provides creative solutions for the cosmetics packaging industry
with high quality manufacturing facilities around the world.

The company is privately-owned and has a manufacturing base situated
on the Mediterranean island of Malta, a plant in China and in 2008 opened manufacturing
facilities in South Korea.

With sales/trading offices in UK, USA, France, Belgium, Italy, Hong Kong, Korea,
and a strong network of alliance partnerships, Toly is able to support
an international customer base in providing innovative
packaging solutions, utilising state-of-the-art technology.

Passionate About Packaging

TOLY-KOREA

www.toly.com | www.tolykorea.com



T1 Line



T1-CSFF/CJFF
[Shut-off Pump]



MATERIAL

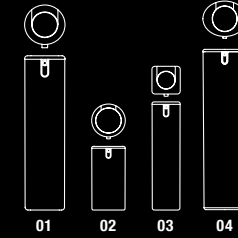

T1-CS / T1-CSFF / T1-CJ / T1-CJFF / T1-SS / T1-OV

- Actuator PP
- Actuator Cover ABS
- Shoulder ABS
- Inner Bottle PP
- Inner Bottle Base HIPS
- Outer Bottle SAN

T1-CSPP / T1-CSPPFF

- Actuator PP
- Actuator Cover ABS
- Shoulder ABS
- Inner Bottle PP
- Inner Bottle Base HIPS
- Outer Bottle PP

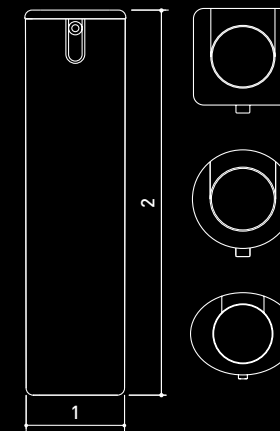

REF.No	Item.No	Capacity	1(mm)	2(mm)
01	T1-10CS	10ml		95.9
	T1-15CS	15ml	28.5	111.4
	T1-20CS	20ml		127.9
	T1-25CS	25ml		109.5
	T1-30CS	30ml	34.5	118.9
	T1-35CS	35ml		128.3
	T1-40CS	40ml	35.8	131.5
01	T1-50CS	50ml		149.3
	T1-25CSFF	25ml		109.5
	T1-30CSFF	30ml		118.9
01	T1-35CSFF		34.5	128.3
	T1-35CSPP	35ml		126.8
01	T1-CSPPFF			127.3
02	T1-30CJ	30ml		89.4
	T1-50CJ	50ml		108.3
	T1-100CJ	100ml		177.5
	T1-120CJ	120ml	46.2	
	T1-30CJFF	30ml		89.4
02	T1-50CJFF	50ml		108.3
	T1-100CJFF	100ml		177.5
	T1-120CJFF	120ml		
03	T1-15SS	15ml	28.5	111.4
	T1-30SS	30ml	34.5	118.9
	T1-50SS	50ml	35.8	149.3
04	T1-30OV	30ml	45.2	118.5
	T1-60OV	60ml	47.1	168.3

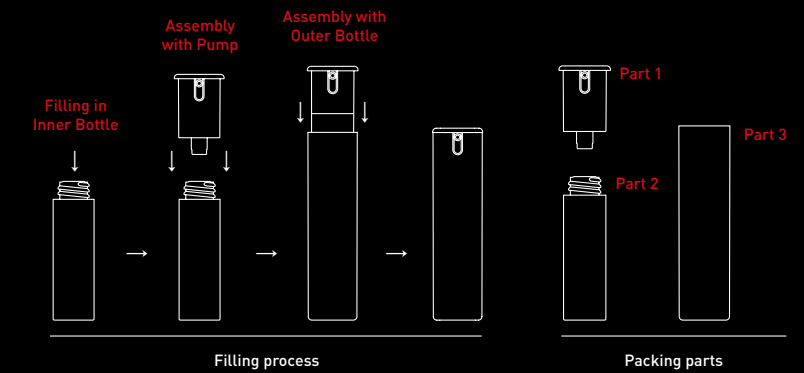

T2 Line



Spray Pump



MATERIAL

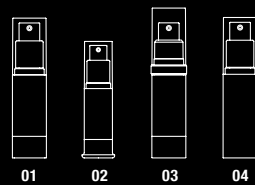

T2-CB / T2-CBR

- Overcap PETG
- Actuator PP+AL(Optional)
- Collar PP+AL(Optional)
- Bottle SAN/PETG
- Base ABS

T2-CSB

- Overcap PETG
- Actuator PP+AL(Optional)
- Shoulder ABS
- Bottle SAN/PETG
- Base ABS

T2-CD

- Overcap PETG
- Actuator PP+AL(Optional)
- Collar PP+AL(Optional)
- Bottle SAN/PETG
- Base HIPS/PETG

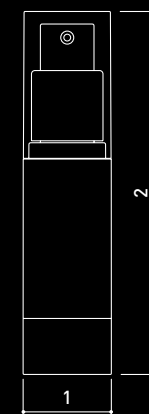

Ref.NO	Item.NO	Capacity	1(mm)	2(mm)
01 T2-CB	T2-15CB	15ml		106.5
	T2-20CB	20ml	26.0	122.0
	T2-25CB	25ml		137.0
	T2-30CB	30ml		113.9
	T2-35CB	35ml	31.0	123.8
	T2-40CB	40ml		133.7
	T2-50CB	50ml		145.0
	T2-60CB	60ml	32.8	161.9
	T2-100CB	100ml	38.9	172.4
	02 T2-CBR	T2-15CBR	15ml	
T2-20CBR		20ml		129.7
T2-25CBR		25ml	26.0	137.5
T2-15CSB		15ml		114.0
T2-20CSB		20ml		129.2
T2-25CSB		25ml		144.0
03 T2-CSB	T2-30CSB	30ml		121.2
	T2-35CSB	35ml	31.0	131.1
	T2-40CSB	40ml		140.7
	T2-50CSB	50ml		151.5
	T2-60CSB	60ml	32.8	168.4
	T2-80CSB	80ml		160.6
	T2-90CSB	90ml	39.2	171.5
	T2-100CSB	100ml		182.3
	T2-15CD	15ml	26.0	107.6
	T2-20CD	20ml		123.9
04 T2-CD	T2-30CD	30ml	31.0	123.5
	T2-35CD	35ml		
	T2-50CD	50ml	32.8	146.2
	T2-100CD	100ml	38.9	175.4

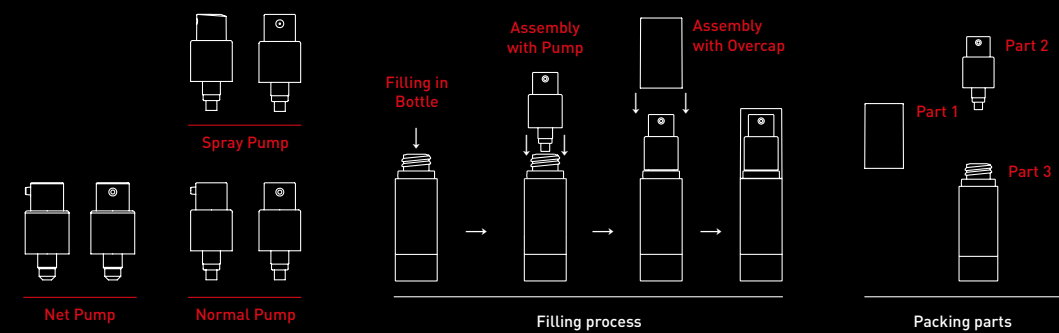

T3 Line



T3-CEBFF/CEDFF
(Shut-off Pump)

MATERIAL

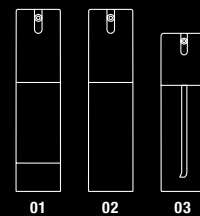

T3-CEB / T3-CEBFF

- Actuator PP
- Actuator Cover ABS
- Shoulder ABS
- Bottle SAN/PETG
- Base ABS

T3-CED / T3-CEDFF

- Actuator PP
- Actuator Cover ABS
- Shoulder ABS
- Bottle SAN/PETG
- Base HIPS/PETG

T3-CET

- Actuator PP
- Actuator Cover ABS
- Shoulder ABS
- Dip Tube PE
- Bottle SAN/PETG

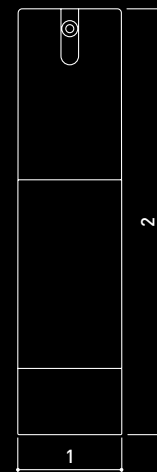

Ref.NO	Item.NO	Capacity	1(mm)	2(mm)	
01	T3-15CEB	15ml	26.0	106.1	
	T3-20CEB	20ml		121.1	
	T3-25CEB	25ml		135.5	
	T3-30CEB	30ml		114.0	
	T3-35CEB	35ml		123.9	
	T3-40CEB	40ml		133.7	
01	T3-50CEB	50ml	32.8	146.1	
	T3-60CEB	60ml		163.1	
	T3-15CEBFF	15ml		26.0	106.1
	T3-20CEBFF	20ml			121.1
	T3-25CEBFF	25ml			135.5
	T3-30CEBFF	30ml			114.0
T3-35CEBFF	35ml	123.9			
T3-40CEBFF	40ml	133.7			
01	T3-50CEBFF	50ml	32.8	146.1	
	T3-60CEBFF	60ml		163.1	
	T3-15CED	15ml		26.0	106.6
	T3-20CED	20ml			123.0
	T3-30CED	30ml			123.6
	T3-35CED	35ml			31.6
T3-50CED	50ml	166.0			
T3-60CED	60ml	182.0			
02	T3-15CEDFF	15ml	26.0	106.6	
	T3-20CEDFF	20ml		123.0	
	T3-30CEDFF	30ml		31.6	146.8
	T3-35CEDFF	35ml			163.1
	T3-50CEDFF	50ml			182.0
	T3-60CEDFF	60ml		201.0	
02	T3-30CET	30ml	31.8	107.0	

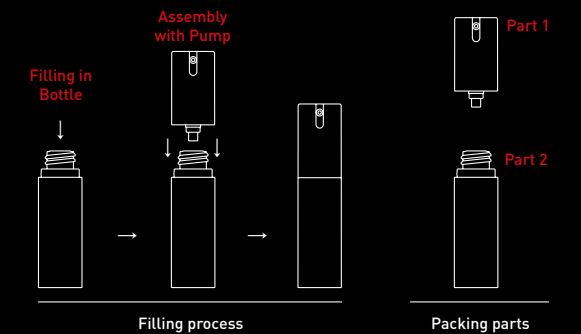

T4 Line



T4-CSFF/T4-CSNFF
(SHUT-OFF PUMP)

MATERIAL

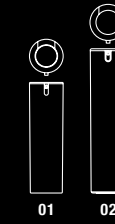

T4-CSN / T4-CSNFF

- Actuator PP
- Actuator Cover ABS
- Shoulder ABS
- Inner Bottle PP
- Inner Bottle Base HIPS
- Outer Bottle SAN

T4-CS / T4-CSFF

- Actuator PP
- Actuator Cover ABS
- Shoulder ABS
- Inner Bottle PP
- Inner Bottle Base HIPS
- Outer Bottle SAN

T4-CSB

- Actuator PP
- Actuator Cover ABS
- Shoulder ABS
- Dip Tube PE
- Inner Bottle PET
- Outer Bottle SAN

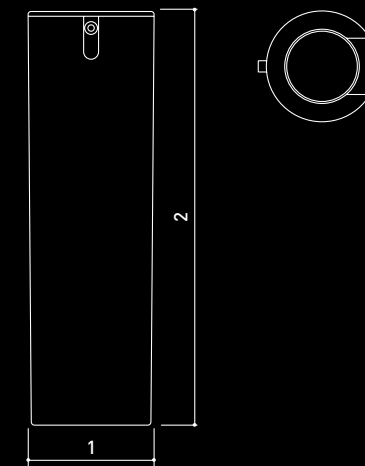

Ref.NO	Item.NO	Capacity	1(mm)	2(mm)
01 T4-CSN	T4-15CSN	15ml	34.0	104.9
	T4-20CSN	20ml		
	T4-30CSN	30ml		
01 T4-CSNFF	T4-15CSNFF	15ml	39.7	104.9
	T4-20CSNFF	20ml		
	T4-30CSNFF	30ml		
01 T4-CS	T4-30CS	30ml	42.0	122.9
	T4-40CS	40ml		
	T4-50CS	50ml		
01 T4-CSFF	T4-60CS	60ml	46.3	130.1
	T4-30CSFF	30ml		
02 T4-CSB	T4-40CSFF	40ml	46.3	130.1
	T4-120CSB(Dip Tube)	120ml		

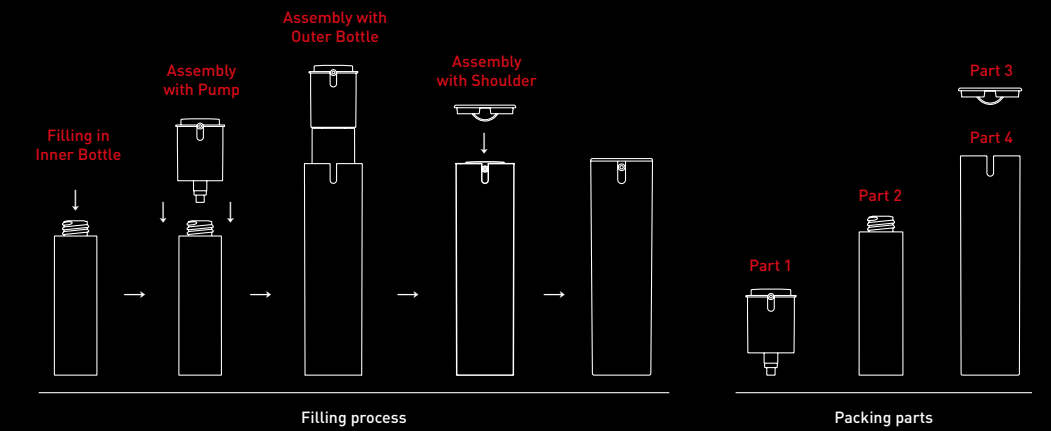

T5 Line

MATERIAL



T5-CS / T5-SS / T5-CJ / T5-CSBK / T5-CJBK

- Overcap PET6/PCTA
- Actuator PP
- Shoulder ABS
- Inner Bottle PP
- Outer Bottle SAN
- Base ABS

T5-CJOF(ON/OFF PUMP)

- Actuator PP
- Shoulder ABS
- Inner Bottle PP
- Outer Bottle SAN
- Base ABS

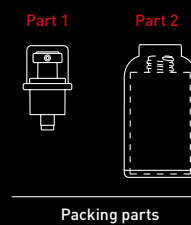
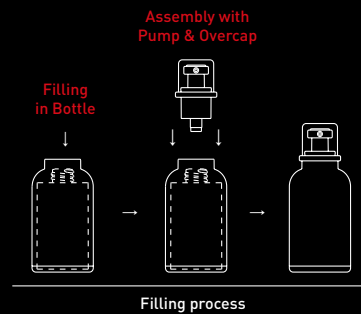
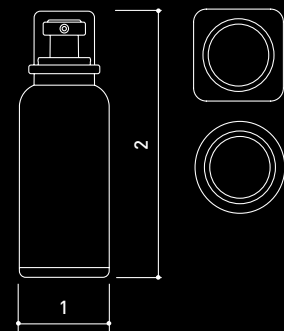

Ref.NO	Item.NO	Capacity	1(mm)	2(mm)
01 T5-CS	T5-30CS	30ml		122.7
	T5-40CS	40ml		135.3
02 T5-SS	T5-30SS	30ml	42.5	122.7
	T5-40SS	40ml		135.3
	T5-50SS	50ml		153.1
03 T5-CJ	T5-120SS	120ml		177.4
	T5-15CJ	15ml		92.8
	T5-30CJ	30ml	48.5	111.5
	T5-50CJ	50ml		123.1
04 T5-CSBK	T5-120CJ	120ml		177.5
	T5-30CSBK	30ml	42.4	123.1
05 T5-CJBK	T5-40CSBK	40ml		135.6
	T5-30CJBK	30ml		93.1
06 T5-CJOF	T5-50CJBK	50ml	48.4	111.8
	T5-120CJBK	120ml		177.8
	T5-50CJOF	50ml	48.3	105.7
	T5-120CJOF	120ml		171.7

T6 Line

MATERIAL

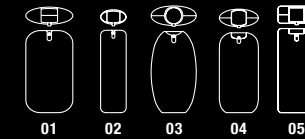

T6-RS / T6-ST / T6-STRS / T6-ST5

- Actuator PP
- Actuator Cover ABS
- Inner Pouch 5 LAYERS (PE+AL+PET)
- Outer Bottle SAN

T6-LC / T6-OV

- Actuator PP
- Actuator Cover ABS
- Shoulder ABS+SAN
- Inner Pouch 5 LAYERS (PE+AL+PET)
- Outer Bottle SAN

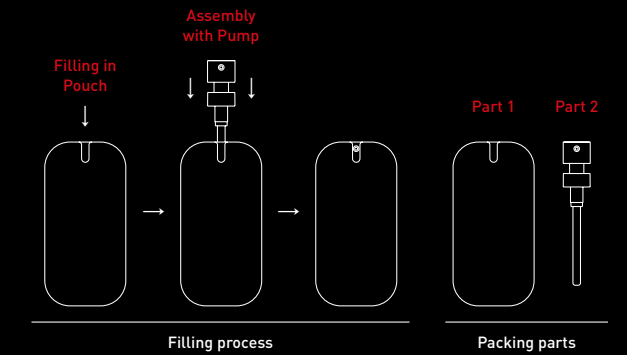
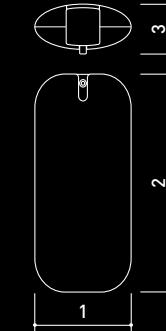

Ref.NO	Item.NO	Capacity	1(mm)	2(mm)	3(mm)
01 T6-RS	T6-35RS	35ml	58.0	117.0	24.2
	T6-15LC	15ml	39.7	115.0	
	T6-20LC	20ml	45.0	105.7	26.0
02 T6-LC	T6-25LC	25ml	39.7	146.8	
	T6-30LC	30ml	45.0	123.7	
	T6-40LC	40ml	52.0	125.9	30.0
	T6-50LC	50ml	53.8	136.1	
03 T6-ST	T6-30ST		58.8	122.5	29.8
04 T6-STRS	T6-40STRS	40ml/30ml	54.5	129.5	28.8
05 T6-ST5	T6-40ST5	40ml	51.5	134.5	27.0

T7 Line

MATERIAL

T7-CS

- Actuator PP
- Shoulder ABS
- Inner Bottle PP
- Inner Base HIPS
- Outer Bottle SAN
- Outer Base ABS

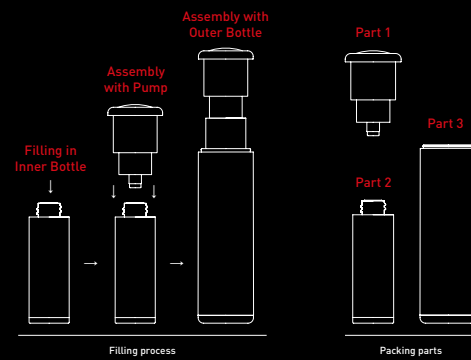
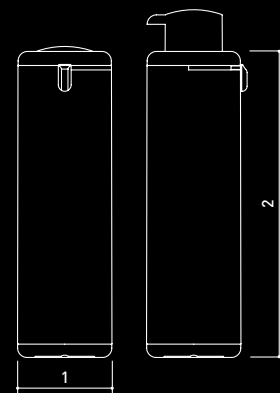

Ref.NO	Item.NO	Capacity	1(mm)	2(mm)
T7-CS	T7-30CS	30ml	40.5	148.9

T8 Line

MATERIAL

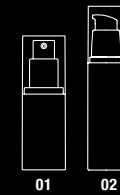

T8-CDSP

- Overcap PP
- Actuator PP+AL(Optional)
- Collar PP+AL(Optional)
- Bottle PP
- Base HIPS

T8-CRD

- Overcap PCTA/ PETG/ SAN
- Actuator PP
- Shoulder ABS
- Bottle PP
- Base HIPS

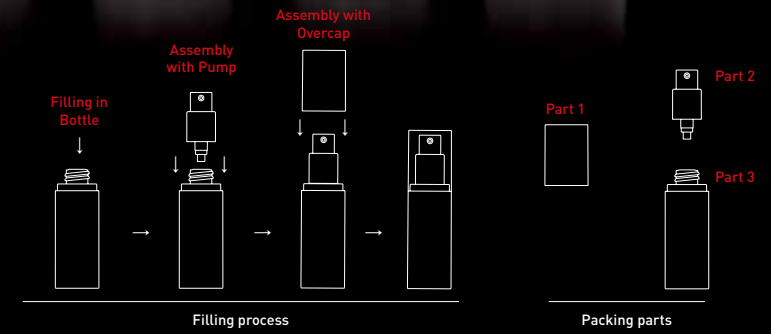
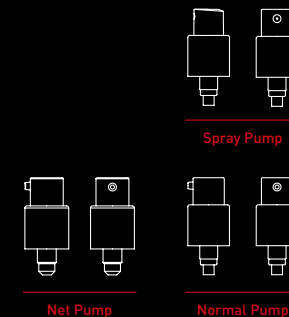
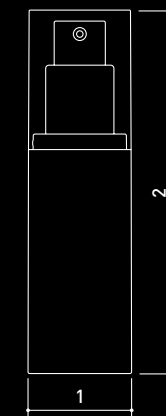

Ref.NO	Item.NO	Capacity	1(mm)	2(mm)
01 T8-CDSP	T8-15CDSP	15ml	32.0	99.1
	T8-20CDSP	20ml		112.1
	T8-30CDSP	30ml		148.1
	T8-50CDSP	50ml		184.1
02 T8-CRD	T8-30CRD	30ml	30.0	133.3

T9 Line (Airless Tube)

MATERIAL

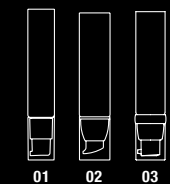

T9-CS

- Overcap: PETG
- Actuator: PP+AL(Optional)
- Collar: PP+AL(Optional)
- Tube: 5 Layers/7 Layers

T9-CSS / T9-CSC

- Overcap: PETG
- Actuator: PP
- Shoulder: PP
- Tube: 5 Layers/7 Layers

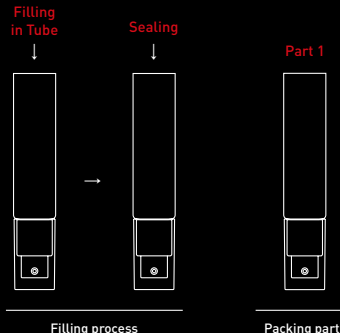
Ref.NO	Item.NO	Capacity	1(mm)
01 T9-CS	T9-19CS	7ml-15ml	ø 19.0
	T9-25CS	15ml-40ml	ø 25.0
	T9-30CS	40ml-60ml	ø 30.0
02 T9-CSS	T9-30CSS	40ml-60ml	ø 30.0
03 T9-CSC	T9-25CSC	15ml-40ml	ø 25.0

T9 Line (Hard Case)

MATERIAL

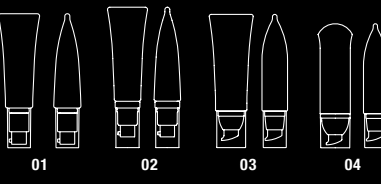

T9-TI

- Overcap: PETG
- Actuator: PP+AL SHELL
- Collar: PP+AL SHELL
- Inner Pouch: 5 LAYERS (PE+AL+PET)
- Outer Bottle: SAN

T9-TIS

- Overcap: PETG
- Actuator: PP
- Shoulder: ABS
- Inner Pouch: 5 LAYERS (PE+AL+PET)
- Outer Bottle: SAN

T9-CRS / T9-CRA

- Overcap: PETG
- Actuator: PP
- Shoulder: PETG
- Inner Pouch: 5 LAYERS(PE+AL+PET)
- Outer Bottle: SAN

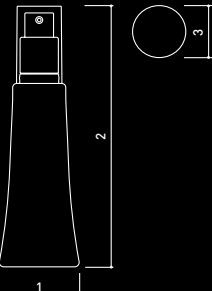
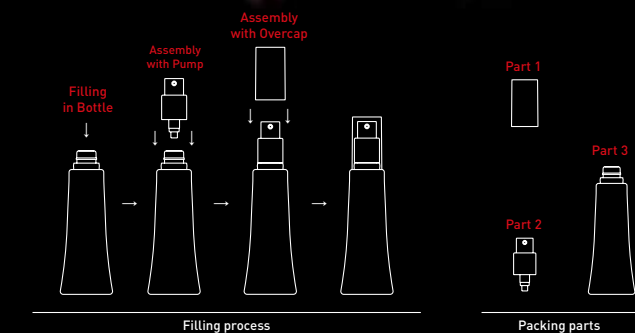



Ref.NO	Item.NO	Capacity	1(mm)	2(mm)	3(mm)
01 T9-TI	T9-30TI	30ml		145.2	
	T9-17TIS	17ml	46.4	132.0	30.4
02 T9-TIS	T9-30TIS	30ml		147.5	
	T9-30CRS	30ml	54.4	158.0	30.2
04 T9-CRA	T9-20CRA	20ml	43.6	132.1	
	T9-30CRA	30ml		156.8	28.0

T10 Line

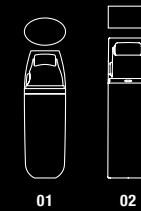

MATERIAL



T10-RSA / RSB / RSC / RSE

- Overcap PETG
- Shoulder PETG
- Inner Pouch 5 LAYERS (PE+AL+PET)
- Outer Bottle SAN
- Applicator RSA NBR Sponge
- RSB Nylon Brush
- RSC PE
- RSE Elastomer
- RSH Elastomer

T10-SG

- Overcap PETG
- Shoulder PP
- Applicator NBR Sponge
- Inner Pouch 5 LAYERS (PE+AL+PET)
- Outer Bottle SAN+ABS

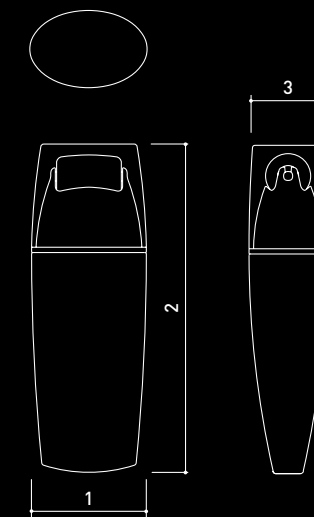

Ref.NO	Item.NO	Capacity	1(mm)	2(mm)	3(mm)	
01 T10-RSA	T10-20RSA	20ml	43.1	118.6	29.0	
	T10-30RSA	30ml		136.6		
01 T10-RSB	T10-20RSB	20ml		129.0	23.5	
	T10-30RSB	30ml		147.0		
01 T10-RSC	T10-20RSC	20ml		129.0	29.0	
	T10-30RSC	30ml		147.0		
01 T10-RSE	T10-20RSE	20ml		129.0	29.0	
	T10-30RSE	30ml		147.0		
02 T10-SG	T10-30SG	30ml		45.1	138.2	22.9

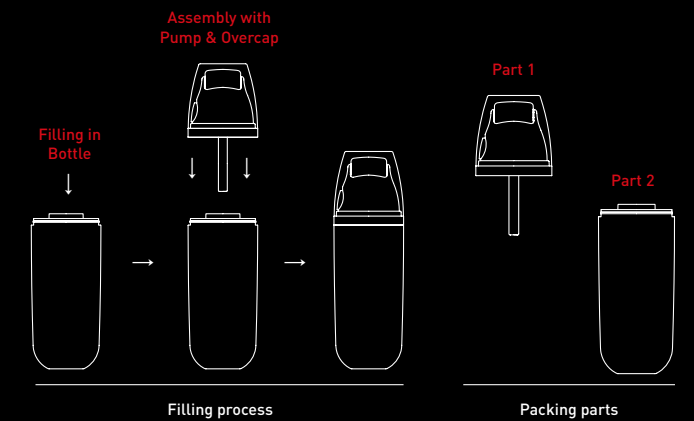
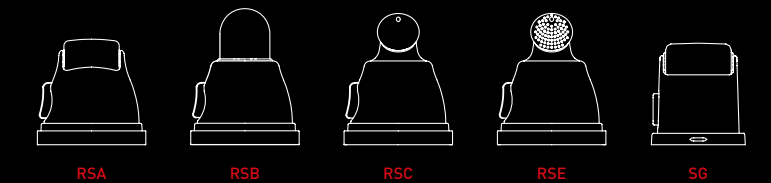

T11 Line

MATERIAL

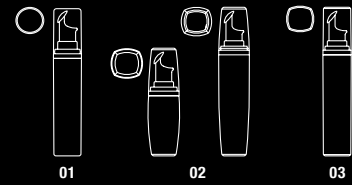

T11-CS / T11-RS / T11-SS

- Overcap PETG
- Shoulder PETG
- Inner Bottle PP
- Outer Bottle SAN
- Applicator H type : PP
- S type : PE
- B type : PP+SUS ball
- R type : PP

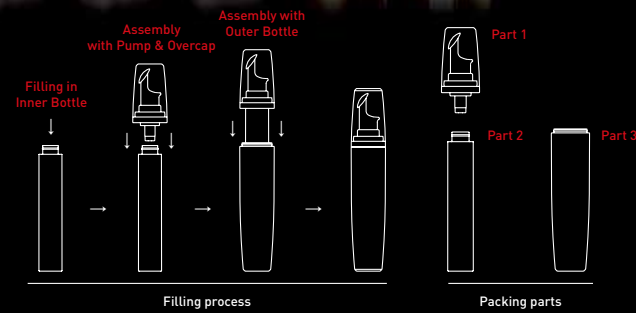
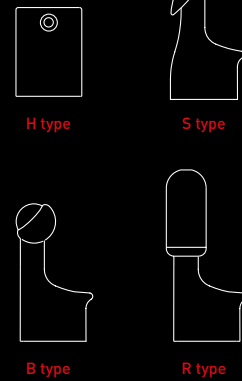
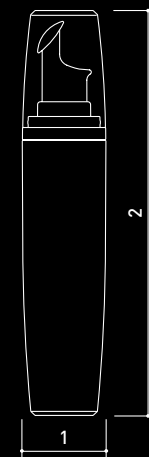

Ref.NO	Item.NO	Capacity	1(mm)	2(mm)
01 T11-CS	T11-15CSS	15ml	23.9	148.7
	T11-15CSB			
	T11-15CSR		24.4	156.8
	T11-15CSH		23.9	148.7
02 T11-RS	T11-5RSS	5ml		
	T11-5RSB			106.4
	T11-5RSH			
	T11-15RSS		28.2	
	T11-15RSB			
03 T11-SS	T11-15RSH	15ml		146.9
	T11-15SSS			
	T11-15SSB		25.4	
	T11-15SSH			

T13 Line

MATERIAL

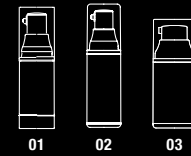

T13-CSE(SHUT-OFF PUMP)

- Overcap SAN
- Actuator PP
- Actuator Cover ABS
- Shoulder ABS
- Bottle PETG
- Base PETG

T13-CSF(SHUT-OFF PUMP)

- Overcap SAN/PETG
- Actuator PP
- Actuator Cover ABS
- Shoulder ABS
- Bottle SAN
- Base ABS

T13-CJF(NORMAL PUMP)

- Overcap SAN/PETG
- Actuator PP
- Shoulder ABS
- Bottle SAN/PETG
- Base ABS

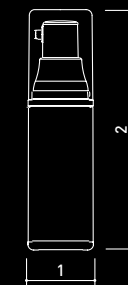

T13-CSE / T13-CSF
(Shut-off Pump)

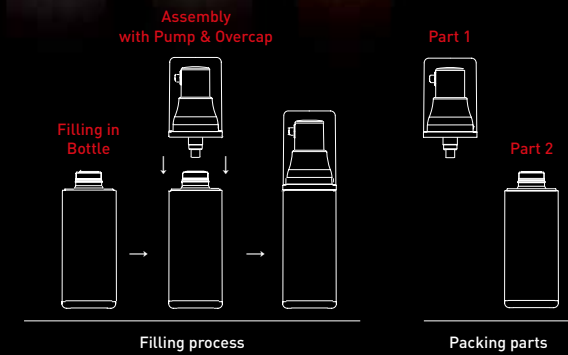

Ref.NO	Item.NO	Capacity	1(mm)	2(mm)
01 T13-CSE	T13-17CSE	17ml	33.0	110.5
	T13-30CSF	30ml		123.6
02 T13-CSF	T13-50CSF	50ml	34.0	158.1
	T13-30CJF	30ml		92.0
03 T13-CJF	T13-50CJF	50ml	43.6	110.5
	T13-120CJF	120ml		175.5

T14 Line

MATERIAL

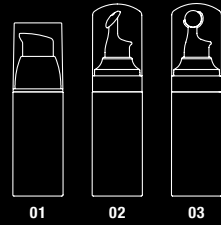

T14-CD / T14-CDS / T14-CDB

- Overcap PP
- Shoulder PP
- Bottle PP
- Base HIPS
- Applicator Pump type : PP
- S type : PE
- B type : PP+SUS ball

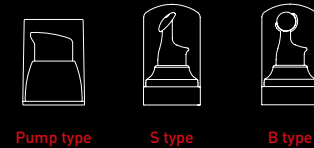
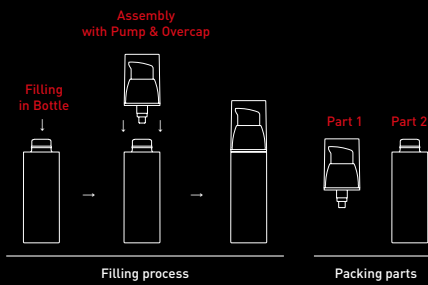
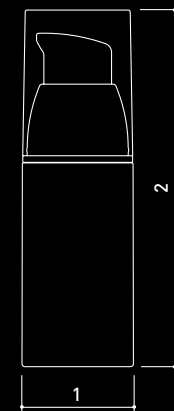

Ref.NO	Item.NO	Capacity	1(mm)	2(mm)
01 T14-CD	T14-20CD	20ml	30.7	97.6
	T14-30CD	30ml		116.1
	T14-40CD	40ml		134.6
	T14-50CD	50ml		153.1
	T14-20CDS	20ml		109.6
02 T14-CDS	T14-30CDS	30ml		128.1
	T14-40CDS	40ml		146.6
	T14-50CDS	50ml		165.1
03 T14-CDB	T14-20CDB	20ml		109.6
	T14-30CDB	30ml		128.1
	T14-40CDB	40ml		146.6
	T14-50CDB	50ml		165.1

T15 Line

MATERIAL

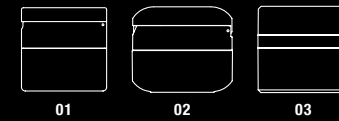

T15-CJB / T15-CJC

- Hinged Lid ABS
- Actuator ABS
- Plate PP
- Shoulder ABS
- Inner Jar PP
- Outer Jar PETG

T15-CJD

- Overcap PETG
- Actuator ABS
- Plate PP
- Shoulder PETG
- Jar PETG

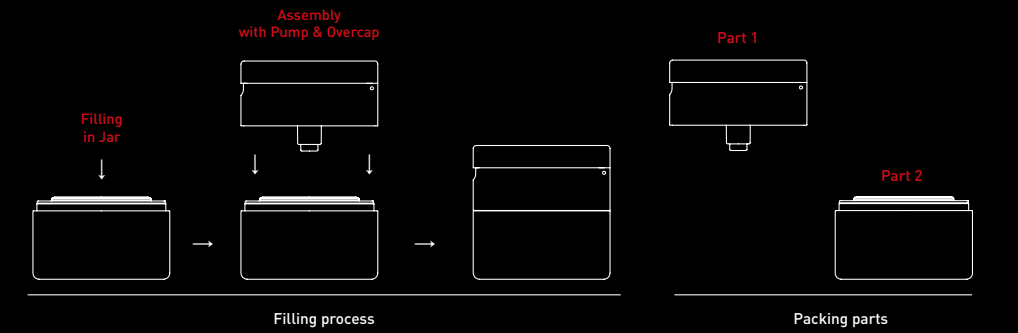
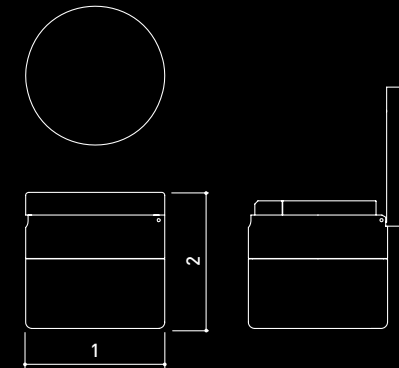

Ref.NO	Item.NO	Capacity	1(mm)	2(mm)	
01 T15-CJB	T15-30CJB	30ml	67.0	64.4	
	T15-50CJB	50ml		72.7	
02 T15-CJC	T15-30CJC	30ml		75.6	64.8
	T15-50CJC	50ml		71.3	
03 T15-CJD	T15-30CJD	30ml		67.0	64.0
	T15-50CJD	50ml			71.0

T16 Line

MATERIAL

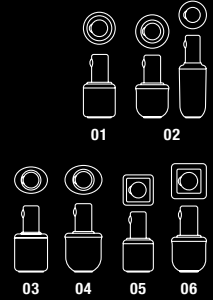

T16-CS / CSR / OV / OVR / SS / SSR

- Dropper Type A type
B type
C type
- Wiper PE
- Shoulder ABS
- Inner Bottle PET (BLOW)
- Outer Bottle SAN

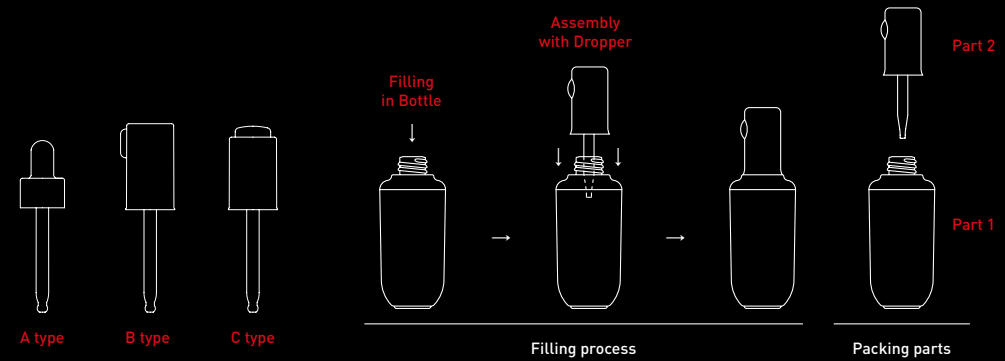
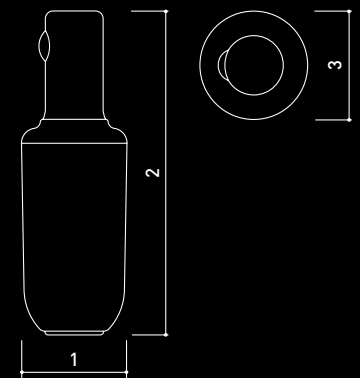

Ref.NO	Item.NO	Capacity	1(mm)	2(mm)	3(mm)
01 T16-CS	T16-30CS	30ml	47.3	95.2	47.3
	T16-30CSR				
02 T16-CSR	T16-40CSR	40ml	42.3	129.8	42.3
03 T16-OV	T16-30OV	30ml	51.5	104.6	39.7
04 T16-OVR	T16-30OVR		51.2	103.5	39.6
05 T16-SS	T16-30SS		47.9	95.4	47.9
06 T16-SSR	T16-30SSR			95.3	

T17 Line

MATERIAL

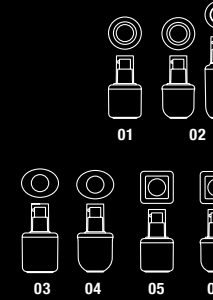

T17-CS / CSR / OV / OVR / SS / SSR

- Overcap PETG
- Actuator PP
- Collar PP+AL SHELL
- Shoulder ABS
- Dip Tube PE
- Inner Bottle PET (BLOW)
- Outer Bottle SAN

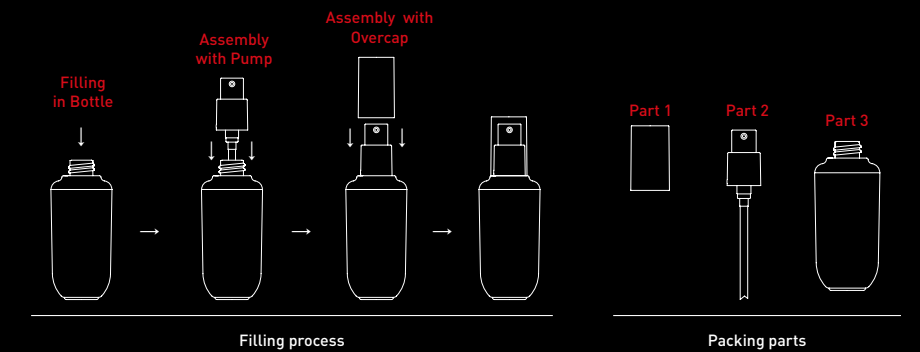
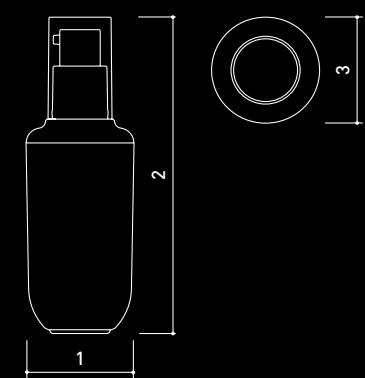

Ref.NO	Item.NO	Capacity	1(mm)	2(mm)	3(mm)
01 T17-CS	T17-30CS	30ml	47.3	94.8	47.3
	T17-30CSR			94.4	
02 T17-CSR	T17-40CSR	40ml	42.3	129.2	42.3
03 T17-OV	T17-30OV	30ml	51.5	104.0	39.7
04 T17-OVR	T17-30OVR		51.2	103.1	39.6
05 T17-SS	T17-30SS		47.9	95.1	47.9
06 T17-SSR	T17-30SSR			94.7	

T18 Line



MATERIAL



T18-CSA / T18-CS / T18-CJ

- Overcap PP
- Actuator PP
- Shoulder PP
- Bottle PP

T18-CJA / T18-CJB / T18-CJD

- Overcap SAN
- Actuator PP
- Shoulder PP
- Bottle SAN

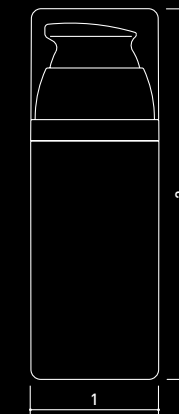

Ref.NO	Item.NO	Capacity	1(mm)	2(mm)
01 T18-CSA	T18-30CSA	30ml	43.0	105.6
	T18-50CSA	50ml		119.3
02 T18-CS	T18-30CS	30ml	43.0	105.6
	T18-50CS	50ml		119.3
03 T18-CJ	T18-100CJ	100ml	52.3	150.4
	T18-120CJ	120ml		168.2
	T18-150CJ	150ml		199.0
04 T18-CJA	T18-110CJA	110ml	51.7	147.0
	T18-100CJB	100ml		150.0
05 T18-CJB	T18-110CJB	110ml	48.0	157.3
	T18-110CJD	110ml		167.8

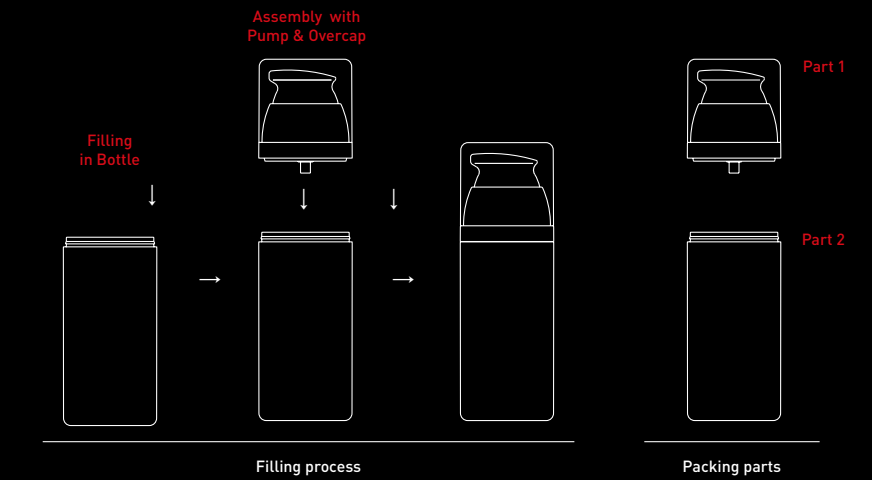

T19 Line

MATERIAL

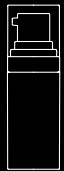

T19-CS

- Overcap: PETG
- Actuator: PP+AL(Optional)
- Shoulder: PCTA
- Dip Tube: PE
- Bottle: SAN/PETG

T19-CSD

- Overcap: PETG
- Actuator: PP+AL(Optional)
- Shoulder: PCTA
- Dip Tube: PE
- Inner Bottle: PP
- Outer Bottle: SAN/PETG

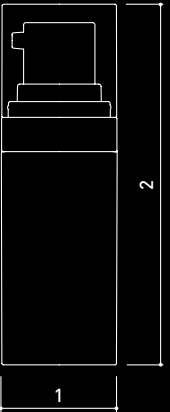

1
2

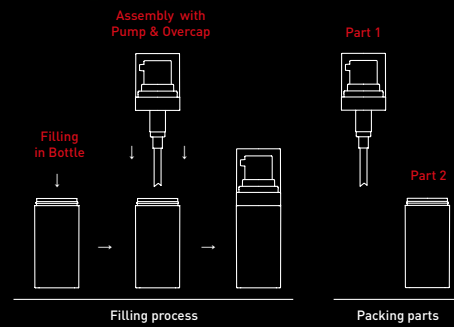

Ref.NO	Item.NO	Capacity	1(mm)	2(mm)
T19-CS	T19-15CS	15ml	25.4	80.3
	T19-20CS	20ml		97.1
	T19-25CS	25ml		111.0
T19-CSD	T19-12CSD	12ml	25.4	80.3
	T19-15CSD	15ml		97.1
	T19-20CSD	20ml		111.0

T20 Line

MATERIAL

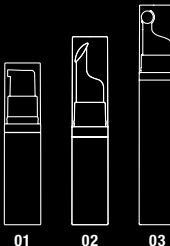

01 02 03

T20-CSH / T20-CSS / T20-CSB

- Overcap: PP
- Shoulder: PP
- Bottle: PP
- Base: PP
- Applicator: H type : PP, S type : PE, B type : PP+SUS ball



1
2

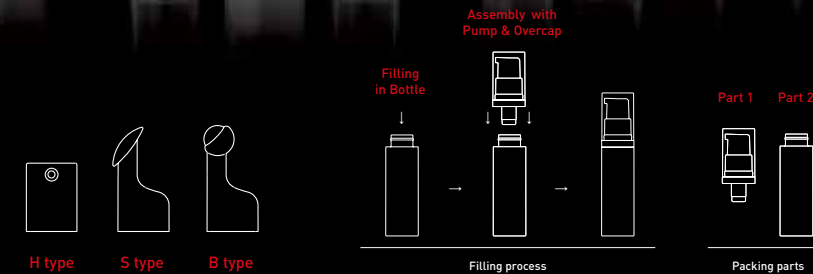

Ref.NO	Item.NO	Capacity	1(mm)	2(mm)
01 T20-CSH	T20-5CSH	5ml	19.2	74.7
	T20-7CSH	7ml		84.7
	T20-10CSH	10ml		99.7
	T20-15CSH	15ml		125.7
02 T20-CSS	T20-5CSS	5ml	19.9	91.4
	T20-7CSS	7ml		101.2
	T20-10CSS	10ml		116.2
03 T20-CSB	T20-5CSB	5ml	19.9	91.4
	T20-7CSB	7ml		101.2
	T20-10CSB	10ml		116.2
	T20-15CSB	15ml		142.2

T21 Line

MATERIAL

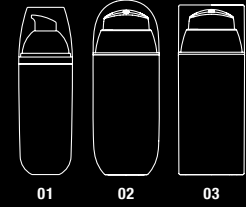

T21-OV

- Overcap PETG
- Actuator PP
- Shoulder PETG
- Inner Pouch 5 LAYERS (PE+AL+PET)
- Outer Bottle SAN

T21-OVA / T21-OVB

- Overcap PETG
- Actuator PP
- Shoulder PP
- Inner Pouch 5 LAYERS (PE+AL+PET)
- Outer Bottle SAN

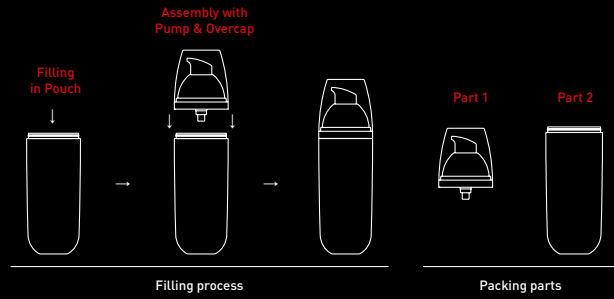
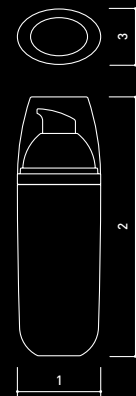

Ref.NO	Item.NO	Capacity	1(mm)	2(mm)	3(mm)
01 T21-OV	T21-200V	20ml	43.1	116.6	28.8
	T21-300V	30ml		134.6	
02 T21-OVA	T21-300VA	30ml	49.1	129.5	29.1
	T21-300VB			125.5	

T23 Line

MATERIAL

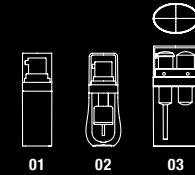

T23-81AP / T23-15CSD

- Overcap PETG
- Actuator PP+AL(Optional)
- Shoulder PCTA
- P-Bottle PP
- V-Valve PE
- Outer Bottle SAN/PETG

T23-8CSE

- Overcap PETG
- Actuator PP+AL(Optional)
- Shoulder PCTA
- P-Bottle PP
- V-Valve PE
- Outer Bottle SAN

T23-150VA

- Overcap PETG
- Actuator PP
- Shoulder PCTA
- Outer Bottle SAN
- P-Overcap PETG
- P-Button PP
- P-Bottle LDPE

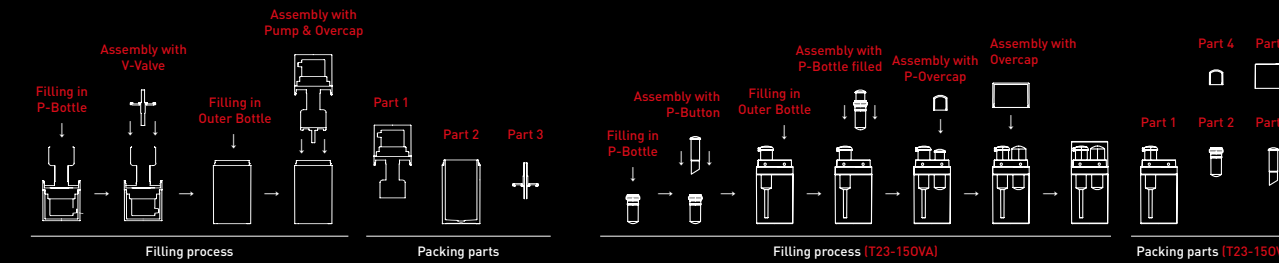
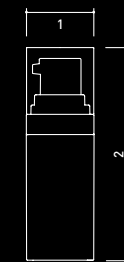

Item.NO	Capacity	1(mm)	2(mm)
01 T23-81AP	P-Bottle : 1.8ml	25.4	80.4
	Outer Bottle : 10ml		
01 T23-15CSD	P-Bottle : 1.8ml	25.4	97.1
	Outer Bottle : 15ml		
02 T23-8CSE	P-Bottle : 1.8ml	32.7	85.4
	Outer Bottle : 8ml		
03 T23-150VA	P-Bottle : 1.3ml	37.0	83.0
	Outer Bottle : 15ml		

T25 Line

MATERIAL

T25-SA

→ Overcap	ABS/SAN/PETG
→ Actuator	PP+AL(Optional)
→ Shoulder	ABS
→ Inner Bottle	PP
→ Outer Bottle	SAN

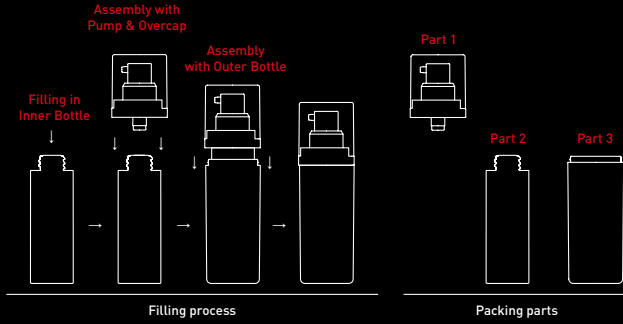
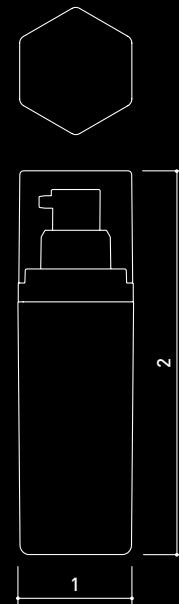

Ref.NO	Item.NO	Capacity	1(mm)	2(mm)
T25-SA	T25-30SA	30ml	37.2	123.1
	T25-50SA	50ml	41.6	150.3
	T25-60SA	60ml		

T26 Line

MATERIAL

T26-CSC

→ Overcap	PETG
→ Actuator	ABS
→ Applicator	NBR Sponge
→ Shoulder	PETG
→ Bottle	PETG
→ Base	PP

T26-CSE

→ Overcap	PETG/PP
→ Actuator	ABS
→ Shoulder	PETG/PP
→ Bottle	PETG/PP
→ Base	PP

T26-CSG

→ Overcap	PP
→ Actuator	ABS
→ Applicator	Nylon Brush
→ Shoulder	PP
→ Bottle	PP
→ Base	PP

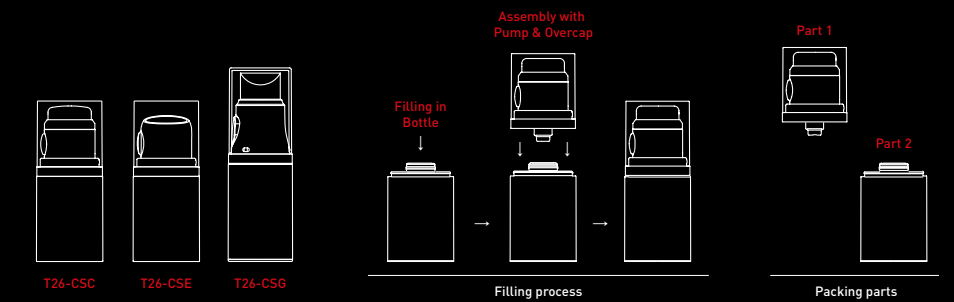
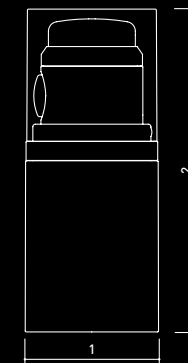

Ref.NO	Item.NO	Capacity	1(mm)	2(mm)
T26-CSC	T26-30CSC	30ml	41.7	100.5
	T26-30CSE	30ml		100.2
T26-CSE	T26-50CSE	50ml	40.15	118.9
	T26-30CSG	30ml	40.2	112.5
T26-CSG	T26-40CSG	40ml		120.0

T27 Line

MATERIAL

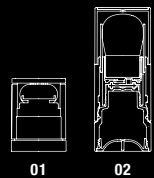

T27-RP

- Overcap PETG
- Shoulder PETG
- Sponge SBR+NBR
- Sponge Holder POM
- Flocking Polyurethan+Nylon
- Sifter PE
- Inner Bottle SAN
- Outer Bottle ABS
- Base ABS

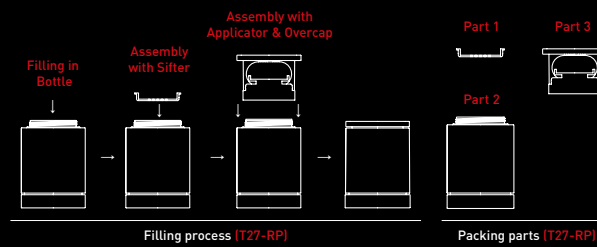
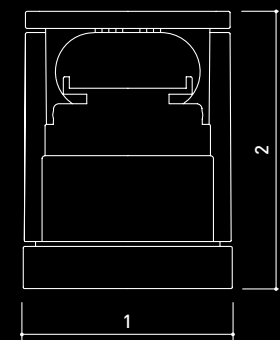

Ref.NO	Item.NO	Capacity	1(mm)	2(mm)
T27-RP	T27-5RP	5g (Powder)	44.5	60.5
	T27-8RP	8g (Powder)		

T28 Line

MATERIAL

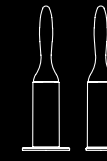

T28-3.5A

- Cap PETG
- Nozzle Cap PE
- Bottle PETG
- Base Piston SILICON

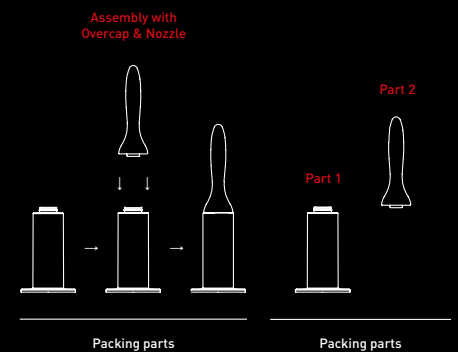
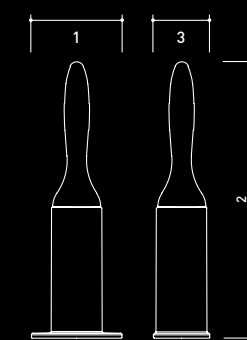

Item.NO	Capacity	1(mm)	2(mm)	3(mm)
T28-3.5A	3.5ml	28.0	85.4	15.6

T30 Line (Wide Neck Bottle)



MATERIAL

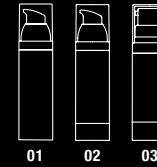

T30-CSAD

- Overcap PETG
- Acuator PP
- Shoulder PETG
- P-Bottle PP
- V-Valve PE
- Dip Tube PE
- Bottle PETG

T30-CSH

- Overcap PETG
- Actuator PP
- Shoulder PETG
- Bottle PETG/SAN
- Base PETG/ABS

T30-CSB

- Overcap PETG
- Actuator PP+AL(Optional)
- Shoulder PETG
- Bottle PETG/SAN
- Base PETG/ABS

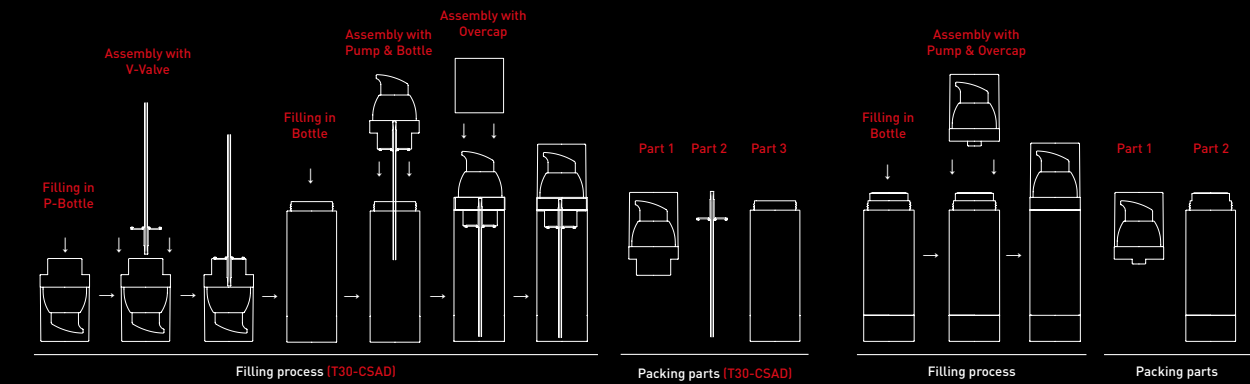
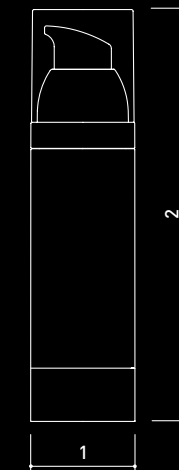

Ref.NO	Item.NO	Capacity	1(mm)	2(mm)
01 T30-CSAD	T30-30CSAD	30ml	32.4	121.0
02 T30-CSH	T30-30CSH	30ml	31.7	119.0
03 T30-CSB	T30-30CSB	30ml	31.7	119.0
	T30-40CSB	40ml	31.7	137.4

T31 Line



T31-CDFF
(Shut-off Pump)

MATERIAL

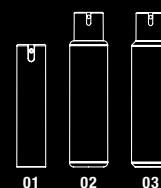

T31-5CD_7CD_10CD

- Actuator PP
- Actuator Cover ABS
- Bottle PETG
- Base HIPS

T31-15CD_30CD_40CD_50CD / T31-CDFF

- Actuator PP
- Actuator Cover ABS
- Bottle PETG
- Base HIPS

T31-CSBA

- Actuator PP
- Actuator Cover ABS
- Shoulder ABS
- Bottle(30ml/50ml) PETG
- Bottle(120ml) SAN
- Base ABS

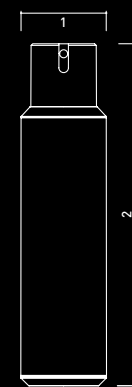

Ref.NO	Item.NO	Capacity	1(mm)	2(mm)
01	T31-5CD	5ml	26.0	76.8
	T31-7CD	7ml		76.8
	T31-10CD	10ml		92.7
	T31-15CD	15ml		108.8
	T31-30CD	30ml		117.0
	T31-40CD	40ml		130.0
01	T31-50CD	50ml	32.8	147.8
	T31-15CDFF	15ml	26.1	108.8
	T31-30CDFF	30ml	31.2	117.0
	T31-40CDFF	40ml	32.8	130.0
	T31-50CDFF	50ml	32.8	147.8
	T31-30CSBA-R	30ml	43.1	88.4
T31-50CSBA-R	50ml	106.9		
T31-120CSBA-R	120ml	171.9		
T31-30CSBA-C	30ml	88.4		
T31-50CSBA-C	50ml	106.9		
T31-120CSBA-C	120ml	171.9		

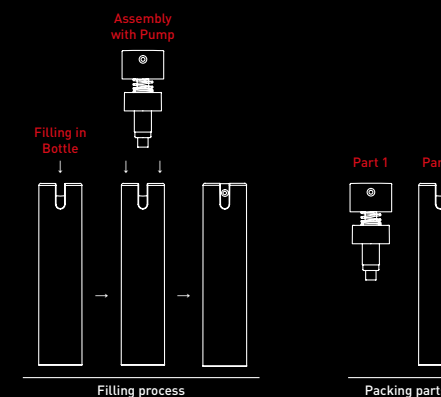

T32 Line (Cushion Compact)



MATERIAL

T32-15ACA / 15ACB / 15ACC / 15ACD

- Outer Lid ABS
- Mirror GLASS
- Platform ABS
- Outer Base ABS
- Button PC
- Refill Inner Lid PP
- Refill Inner Base PP
- Refill Ring PP

T32-13ACD-N

- Plaque PC
- Outer Lid ABS
- Mirror GLASS
- Platform ABS
- Outer Base ABS
- Button PC
- Refill Inner Lid PP
- Refill Inner Base PP
- Refill Gasket NBR
- Refill Net Ring PP+Nylon

T32-100WC

- Outer Lid ABS
- Mirror GLASS
- Platform ABS
- Outer Base ABS
- Button PC
- Refill Inner Lid PP
- Refill Inner Base PP
- Refill Ring PP

T32-8ACC-S / 8ACR-S

- Outer Lid ABS
- Mirror GLASS
- Outer Base ABS
- Refill Lid PP
- Cover Ring PE
- Refill Base PP

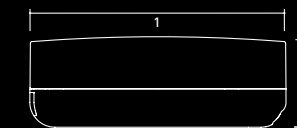

Item.NO	Capacity	1(mm)	2(mm)
T32-15ACA	15g		28.5
T32-15ACB	15g		28.8
T32-15ACC	15g	77.0	27.2
T32-15ACD	15g		28.8
T32-13ACD-N	13g		28.8
T32-100WC	25g	99.8	23.5
T32-8ACC-S	25g	63.5	24.1
T32-8ACR-S	25g	63.5	23.6

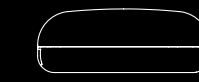

T32-15ACA

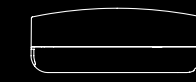

T32-15ACB

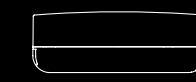

T32-15ACC

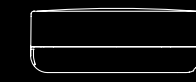

T32-15ACD

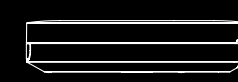

T32-100WC

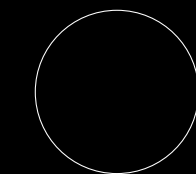

T32-8ACC-S

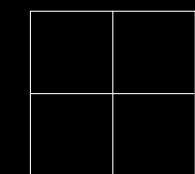

T32-8ACR-S

T34 Line

MATERIAL

T34-JA

→ Outer Cap	SAN
→ Inner Cap	PP
→ Shive	LDPE
→ Inner Jar	PP
→ Outer Jar	SAN

T34-CSA

→ Overcap	SAN / PETG
→ Actuator	PP+AL(Optional)
→ Collar	ABS
→ Shoulder	ABS
→ Inner Bottle	PP
→ Outer Bottle	SAN

T34-120CJA

→ Overcap	SAN / PETG
→ Actuator	PP+AL(Optional)
→ Collar	ABS
→ Shoulder	ABS
→ Dip Tube	LDPE
→ Inner Bottle	PET
→ Outer Bottle	SAN

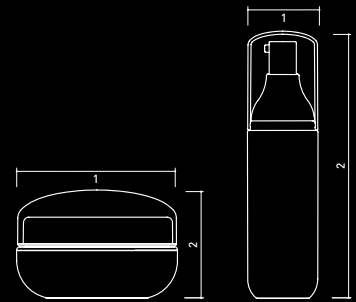

Ref.NO	Item.NO	Capacity	1(mm)	2(mm)
T34-JA	T34-30JA	30ml	66.1	44.2
	T34-50JA	50ml	76.1	50.2
T34-CSA	T34-30CSA	30ml	38.4	130.2
	T34-50CSA	50ml	165.2	
T34-CJA	T34-120CJA	120ml	45.3	186.0

T38 Line (Tube Stick)

MATERIAL

T38-40BST

→ Stick Cap	PP
→ Stick Body	PP
→ Tube Cap	PP
→ Tube Applicator	PE
→ Tube Shoulder	PP
→ Tube	BLOW

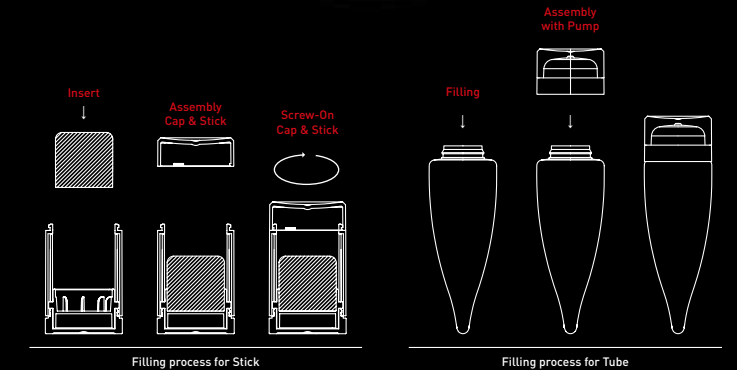

Item.NO	Capacity	1(mm)	2(mm)
T38-40BST	4g with Brush/ 8g without	ø 35	60.0

T39 Line (Side by Side Cushion Compact)

MATERIAL

T39-123DACA

→ Outer Lid	ABS
→ Mirror	GLASS
→ Platform	ABS
→ Outer Base	ABS
→ Button	PC
→ Refill Inner Lid	PP
→ Refill Inner Base	PE
→ Refill Ring	PE

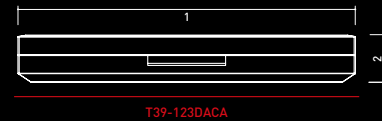

Item.NO	Capacity	1(mm)	2(mm)
T39-123DACA	12ml/ 3ml	130.0	18.0

T46 Line

MATERIAL

T46-50CS / T46-60CS

→ Overcap	PETG
→ Actuator	PP
→ Shoulder	ABS
→ Bottle	SAN / PETG
→ Base	ABS

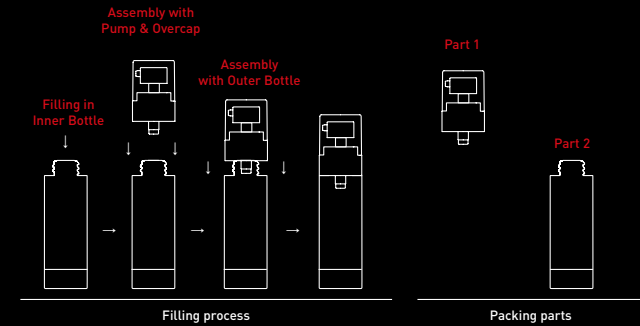
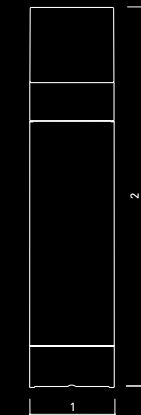

Item.NO	Capacity	1(mm)	2(mm)
T46-50CS	50ml	32.8	146.5
T46-60CS	60ml	32.8	163.5

Refillable Airless

MATERIAL

TK-RF

- Overcap PETG
- Actuator PP
- Actuator Cover ABS
- Shoulder ABS
- Inner Bottle PP
- Outer Bottle SAN

REFILL BOTTLE

- Cap PP
- Bottle PP

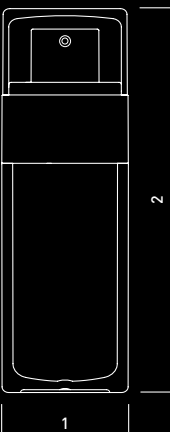







Ref.NO	Item.NO	Capacity	1(mm)	2(mm)
TK-RF	TK-RF30A	30ml		120.5
	TK-RF40A	40ml	38.0	136.7
	TK-RF50A	50ml		152.9

Dual Airless

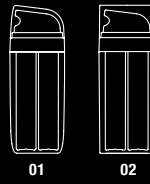
MATERIAL



TK-D30 / TK-D30-1

- Overcap PP
- Actuator PP
- Shoulder PP
- Inner Bottle PP
- Outer Bottle PP

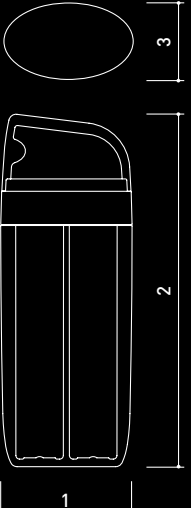





Item.NO	Capacity	1(mm)	2(mm)	3(mm)
⁰¹ TK-D30				
⁰² TK-D30-1	15ml+15ml	53.9	142.2	31.9

Airless Bag in Hard Case

MATERIAL

TK-OV30BC / TK-OV40BC

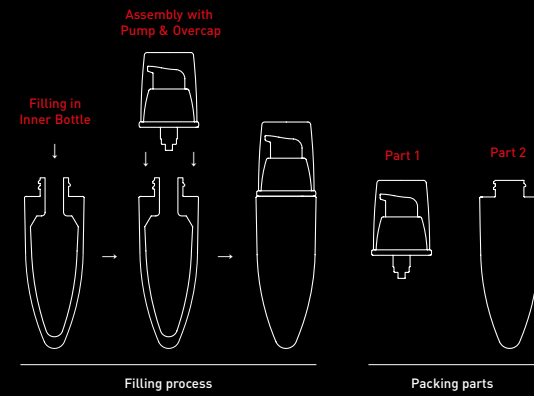
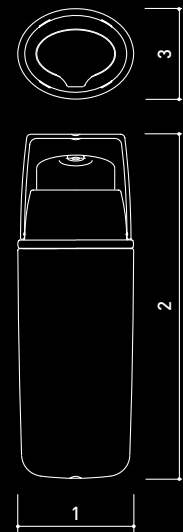
- Overcap PETG
- Actuator PP
- Shoulder PP
- Inner Pouch PE (BLOW)
- Outer Bottle PETG/PP



Item.NO	Capacity	1(mm)	2(mm)	3(mm)
TK-OV30BC	30ml		124.8	
TK-OV40BC	30ml/40ml	42.3	137.9	33.0

Dial Airless Jar

MATERIAL

TK-50DA

- Overcap PETG
- Plate PP
- Dial ABS
- Outer Bottle SAN
- Inner Bottle PP

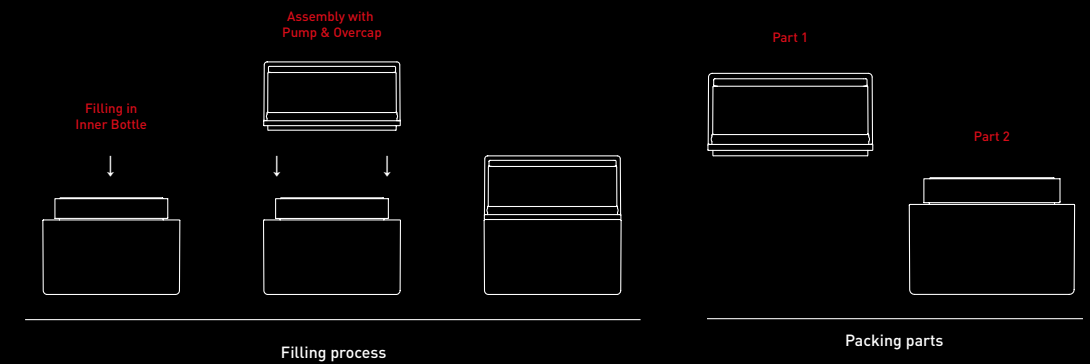

Item.NO	Capacity	1(mm)	2(mm)
TK-50DA	50ml	68.0	68.7

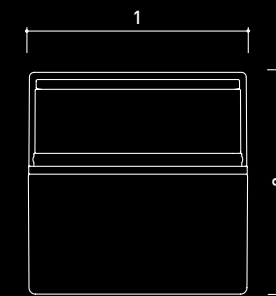

Dual Blender (Refillable)

MATERIAL

- TK-252RD**
- Overcap PETG
 - Nozzle Cover NBR
 - Plate PP
 - Dial ABS
 - Outer Bottle ABS
 - Inner Bottle PET (BLOW)
 - Base ABS
 - Refill Overcap PP

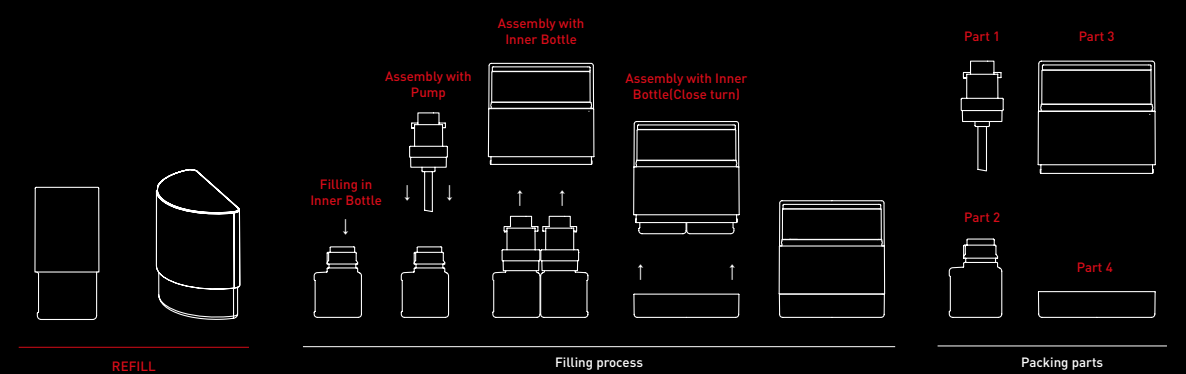
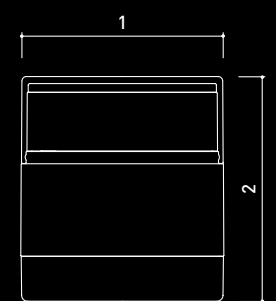

Item.NO	Capacity	1(mm)	2(mm)
TK-252RD	25ml+25ml	68.0	75.1
REFILL	25ml	32.7	68.4

Onsen Massager

MATERIAL

- ONSEN (Inner Bottle)**
- Bottle PETG/PP
 - Shoulder PP
 - Actuator PP
 - Cap PETG/PP

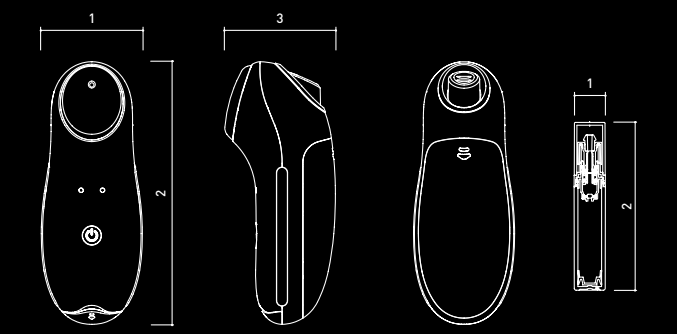

Item.NO	Capacity	1(mm)	2(mm)	3(mm)
ONSEN MASSAGER	-	47.2	122.6	51.6
ONSEN - INNER BOTTLE	5ml	16.7	89.6	-

INJECTION BLOW LINE 1

(Pump / Single cap / Double cap / Cylindrical bottle)



MATERIAL	
CAP	
Single Wall	
→ Cap (180 Pump)	PETG
→ Cap (200 Pump)	PP
Double Wall (200 Pump)	
→ Outer Cap	ABS
→ Inner Cap	PP
ESSENCE/ OIL PUMP	
→ Actuator	PP
→ Collar	PP
→ Collar Cover	AL (Optional)
→ Stopper (Oil pump only)	PP
→ Dip tube	PE
SPRAY PUMP	
→ Actuator	PP
→ Collar	PP
→ Dip tube	PE
BOTTLE	
→ Bottle	PET

OVERCAP

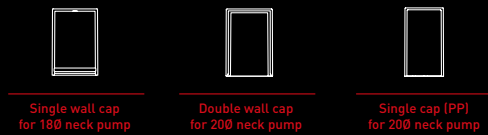

PUMP

Essence

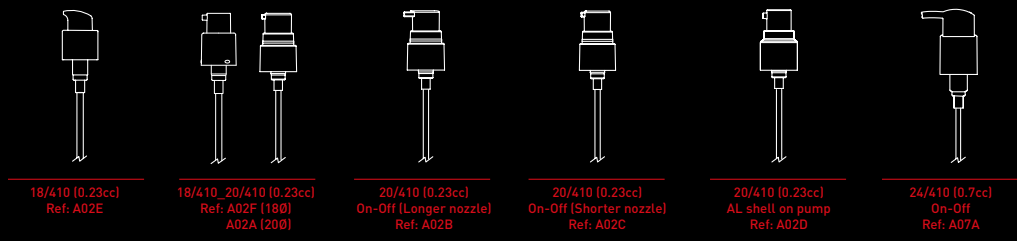

Spray

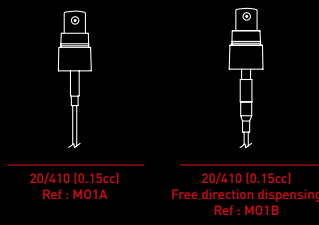

Oil

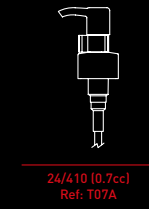

BOTTLE

	TH01: Heavy wall	[18/410] 20ml/ 30ml/ 50ml	TI01: Thin wall	[20/410] 50ml/ 100ml
		[20/410] 30ml/ 50ml/ 100ml/ 130ml/ 150ml/ 200ml		[24/410] 100ml/ 150ml/ 200ml/ 250ml/ 300ml
		[24/410] 200ml/ 250ml	TI07: Thin wall	[24/410] 200ml

Ref No. **TH01-XXXYYZZZZ-00**

Heavy wall bottle
Thin wall bottle

Neck Ref. ex) 18; 180; 20; 200; 24; 240
Pump Ref. ex) M01A; T02A; A02A
Other Ref.

Filling volume ex) 030: 30ml; 100: 100ml; 250: 250ml

INJECTION BLOW LINE 2

(Pump / Single cap / Double cap / Round Shoulder bottle)



MATERIAL	
CAP	
Single Wall	
→ Cap	PP
Double Wall	
→ Outer Cap	ABS
→ Inner Cap	PP
ESSENCE/ OIL PUMP	
→ Actuator	PP
→ Collar	PP
→ Collar Cover	AL (Optional)
→ Stopper (Oil pump only)	PP
→ Dip tube	PE
SPRAY PUMP	
→ Actuator	PP
→ Collar	PP
→ Dip tube	PE
BOTTLE	
→ Bottle	PET

OVERCAP

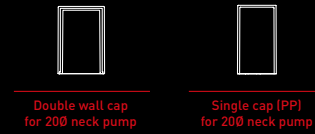

PUMP

Essence

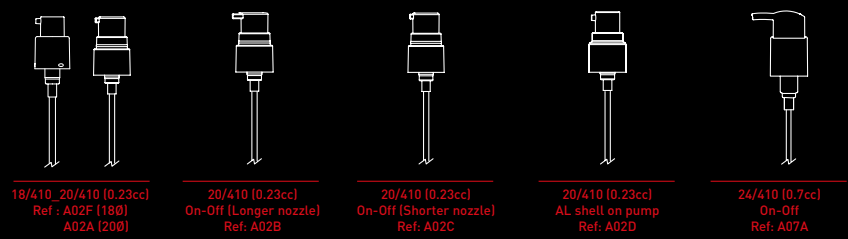

Spray

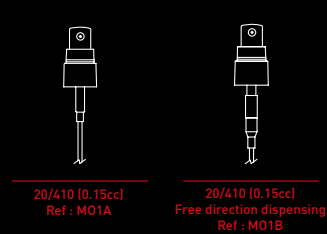

Oil

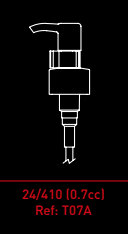

BOTTLE

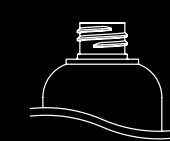

TH02: Heavy wall

[20/410]
30ml/ 50ml/ 100ml/ 130ml/ 150ml/ 200ml
[24/410]
200ml/ 250ml

T102: Thin wall

[20/410]
100ml
[24/410]
100ml/ 120ml/ 150ml/ 200ml/ 250ml

Ref No.

TH02-XXXYYZZZZ-00

Heavy wall bottle

T102
Thin wall bottle

Neck Ref.
ex) 20 : 200
24 : 240

Filling volume
ex) 030: 30ml
100: 100ml
250: 250ml

Pump Ref.
ex) M01A
T02A
A02A

Other Ref.

INJECTION BLOW LINE 3

(Pump / Flush cap / Cylindrical bottle)



MATERIAL

CAP

Single Wall
- Flush cap PETG

ESSENCE / OIL PUMP

- Actuator PP
- Collar PP
- Collar Cover AL (Optional)
- Stopper (Oil Pump only) PP
- Dip Tube PE

SPRAY PUMP

- Actuator PP
- Collar PP
- Dip tube PE

BOTTLE

- Bottle PET

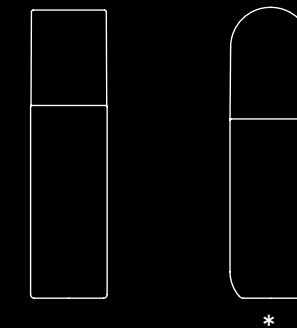

OVERCAP



Single cap (PETG) for THB03 bottle



Single cap (PETG) for THB05 bottle *

PUMP

Essence



18/410 (0.23cc) Ref: A02E

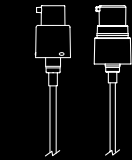

18/410_20/410 (0.23cc) Ref: A02F (180) A02A (200)



20/410 (0.23cc) On-Off (Longer nozzle) Ref: A02B



20/410 (0.23cc) On-Off (Shorter nozzle) Ref: A02C



20/410 (0.23cc) AL shell on pump Ref: A02D

Spray

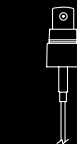

20/410 (0.15cc) Ref: M01A

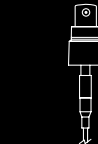

20/410 (0.15cc) Free direction dispensing Ref: M01B

BOTTLE

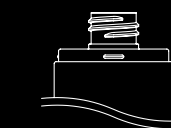

TH03: Heavy wall

[20/410] 30ml/ 50ml/ 100ml/ 130ml/ 150ml

* TH05: Heavy wall

[20/410] 100ml

[24/410] 200ml/ 250ml

Ref No.

TH03-XXXYYZZZZ-00

Heavy wall bottle

TH05

Heavy wall bottle

Neck Ref.
ex) 18: 180
20: 200
24: 240

Filling volume
ex) 030: 30ml
100: 100ml
250: 250ml

Pump Ref.
ex) M01A
T02A
A02A

Other Ref.

INJECTION BLOW LINE 4

(Reducer, Flip top cap)



MATERIAL	
CAP	
Flip top Cap	PP
Screw Cap	
- Single Wall	PP
- Double Wall(Outer)	ABS
- Double Wall(Inner)	PP
REDUCER(SCREW CAP)	
- Reducer	LDPE
BOTTLE	
- Bottle	PET

CAP

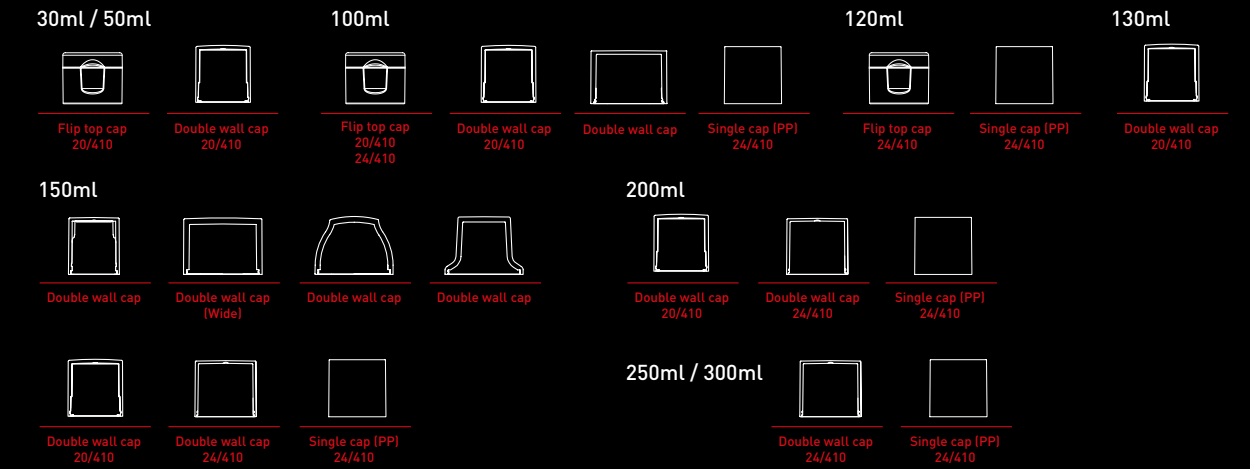

REDUCER

	Hole Size	Neck Size	Bottle Volume
	10.7Ømm	-	100ml
	12.8Ømm	20/410	30ml/50ml
	13.5Ømm	-	150ml
	15.2Ømm	20/410	100ml/130ml/150ml/200ml
	18.4Ømm	24/410	100ml/120ml/150ml/ 200ml/ 250ml/ 300ml

BOTTLE

	TH01: Heavy wall	[20/410] 30ml/ 50ml/ 100ml/ 130ml/ 150ml/ 200ml	T101: Thin wall	[20/410] 50ml/ 100ml
	TH02: Heavy wall	[20/410] 30ml/ 50ml/ 100ml/ 130ml/150ml/ 200ml	T102: Thin wall	[20/410] 50ml/ 100ml
		[24/410] 200ml/ 250ml		[24/410] 100ml/ 150ml/ 200ml/ 250ml/ 300ml
		[24/410] 200ml/ 250ml		[24/410] 100ml/ 120ml/ 150ml/ 200ml/ 250ml

FLIP TOP CAP + BOTTLE



INJECTION BLOW LINE 5

(Cylindrical Cream Jar)



MATERIAL

TH01-CJ

→ Cap PP / ABS / AL
 → Shive LDPE
 → Press Shive PET/ PS
 → Jar PET

T101-300CJ-01

→ Cap(Flip top) PP
 → Press Shive PET
 → Jar PET

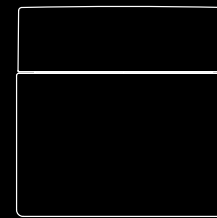

CAP

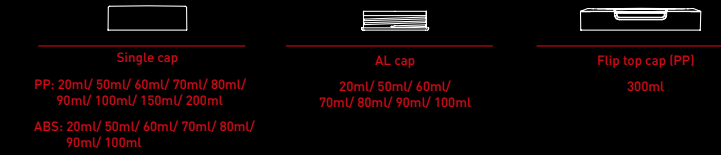

SHIVE

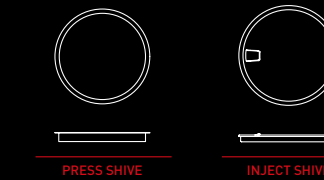

JAR

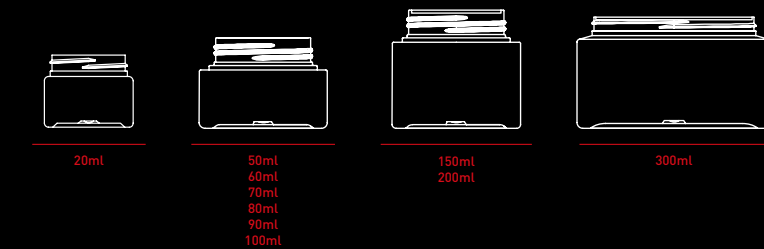

Ref No.

TH01-XXXCJ-00

Heavy wall jar

T101

Thin wall jar

Other Ref.

Cream Jar

Filling volume
 ex) 020: 20ml
 100: 100ml
 300: 300ml

INJECTION BLOW LINE 6

(Round Shoulder Cream Jar)



MATERIAL

TH02-CJ

- Cap PP
- Shive LDPE
- Jar PET

Item.NO	Capacity	1(mm)	2(mm)
TH02-050CJ-01	50ml	33.0	47.0
TH02-100CJ-01	100ml	65.6	60.4
TH02-150CJ-01	150ml	74.9	65.9
TH02-200CJ-01	200ml	83.1	67.5

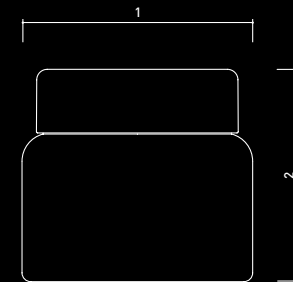

INJECTION BLOW LINE 7

Applicator

MATERIAL



TH01-FS

- Sponge cap ABS
- Sponge NBR
- Outer cap ABS
- Inner cap PP
- Spatula PP
- Bottle PET

TH01-FF

- Outer cap ABS
- Inner cap w/ Rod PP
- Tip Flocking Sponge
- Wiper LDPE
- Bottle PET

TH01-JA

- Outer cap PCTA
- Inner cap w/ Rod PP
- Tip Elastomer + PP
- Wiper Elastomer + PP
- Bottle PET

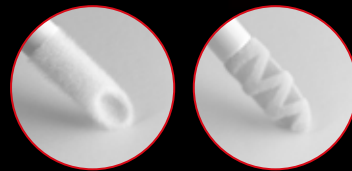
DOE FOOT
(TH01-JA-01)

JAALI
(TH01-JA-02)

Item.NO	Capacity	1(mm)	2(mm)
TH01-030FS-01	30ml	41.0	76.9
TH01-030FF-01	30ml	33.0	93.7
TH01-050FF-01	50ml	33.0	129.1
TH01-030JA-01/ 02	30ml	33.0	98.5
TH01-040JA-01/ 02	40ml	33.0	111.6
TH01-050JA-01/ 02	50ml	33.0	133.5

TH: HEAVY WALL BOTTLE

INJECTION BLOW LINE 8

Dropper

MATERIAL

TH01-DR/ TH02-DR

- Teat NBR / Silicon / Elastomer
- Hole cap PP
- Hole cap Cover AL
- Pipette Glass
- Wiper LDPE
- Bottle PET

TI01-DR

- Teat Elastomer
- Hole cap PP
- Hole cap Cover AL (Optional)
- Pipette PP
- Bottle PET

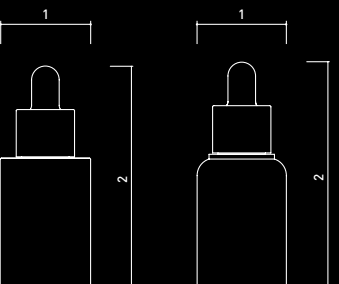

Item.NO	Capacity	1(mm)	2(mm)
TI01-00713DR-01/ 02	7ml	19.8	64.2
TH01-03020DR-01/ 02/ 03	30ml	33.0	103.0
TH01-03020DR-04/ 05/ 06	30ml	38.0	95.7
TH01-05020DR-01/ 02/ 03	50ml	33.0	138.0
TH01-05020DR-04/ 05/ 06	50ml	38.0	119.2
TH02-03020DR-01/ 02/ 03	30ml	37.6	97.5
TH02-03020DR-04/ 05/ 06	30ml	36.7	95.7
TH02-05020DR-01/ 02/ 03	50ml	37.5	121.4

TH : HEAVY WALL BOTTLE
TI : THIN WALL BOTTLE

TK01 Boston Line

MATERIAL

TK01-015CJ-01_02 / TK01-020CJ-01_02

- Outer Cap SAN / ABS
- Inner Cap ABS
- Shive PE
- Inner Jar PP
- Outer Jar SAN

TK01-050CJ-01_02

- Outer Cap SAN / ABS
- Inner Cap ABS / PP
- Shive PE
- Inner Jar PP
- Outer Jar SAN

TK01-DT

- Overcap SAN / PETG / ABS
- Actuator PP
- Collar PP
- Dip Tube PE
- Shoulder ABS
- Inner Bottle PET(Blow)
- Outer Bottle SAN

TK01-BT

- Outer Cap SAN / ABS / PMMA
- Inner Cap PP
- Reducer PE
- Shoulder ABS
- Inner Bottle PETG(Blow)
- Outer Bottle SAN / PMMA

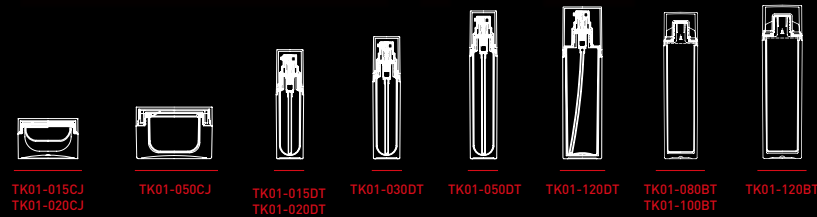
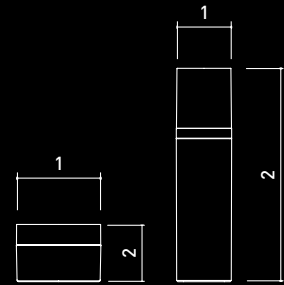

Item.NO	Capacity	1(mm)	2(mm)
TK01-015CJ-01	15ml		
TK01-015CJ-02		58.1	38.5
TK01-020CJ-01	20ml		
TK01-020CJ-02			
TK01-050CJ-01	50ml	74.0	50.1
TK01-050CJ-02			
TK01-015DT	15ml		
TK01-020DT	20ml		114.4
TK01-030DT	30ml	32.3	143.2
TK01-050DT	50ml		171.3
TK01-120DT	120ml	45.8	177.6
TK01-080BT	80ml	40.4	171.2
TK01-100BT	100ml		
TK01-120BT	120ml	47.0	177.6

TK02 Versailles Line

MATERIAL

TK02-CJ

- Outer Cap SAN / ABS
- Inner Cap PP
- Shive PE
- Inner Jar PP
- Outer Jar SAN

TK02-DT

- Overcap SAN / ABS / PETG
- Actuator PP
- Collar PP
- Dip Tube PE
- Shoulder ABS
- Inner Bottle PET(Blow)
- Outer Bottle SAN

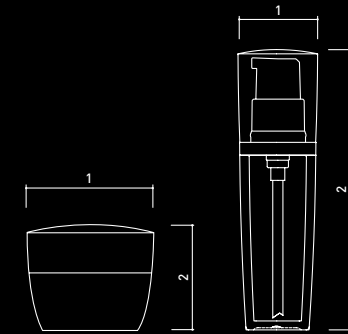
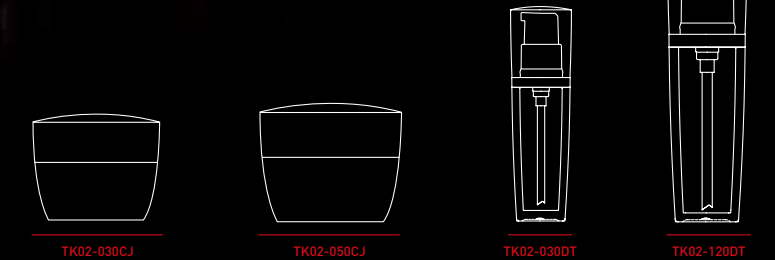

Item.NO	Capacity	1(mm)	2(mm)
TK02-030CJ	30ml	64.0	46.1
TK02-050CJ	50ml	72.4	53.6
TK02-030DT	30ml	38.4	130.8
TK02-120DT	120ml	50.2	188.7

TK03 Monaco Line (Oval Shape)

MATERIAL

TK03-CJ

- Outer Cap ABS
- Inner Cap PP
- Shive PE
- Inner Jar PP
- Outer Jar SAN

TK03-DT

- Overcap PETG
- Actuator PP
- Collar PP
- Dip Tube PE
- Shoulder ABS
- Inner Bottle PET(Blow)
- Outer Bottle SAN



Item. NO	Capacity	1(mm)	2(mm)	3(mm)
TK03-005CJ	5ml			
TK03-007CJ	7ml	53.5	34.2	46.0
TK03-010CJ	10ml			
TK03-030CJ	30ml	72.3	46.9	60.4
TK03-050CJ	50ml	78.5	51.5	68.0
TK03-050DT	50ml		115.9	40.7
TK03-120DT	120ml	50.7	181.4	

TK04 Emma Line

MATERIAL

TK04-005CJ_007CJ_010CJ_015CJ

- Cap ABS
- Shive PE
- Inner Jar PP
- Outer Jar SAN

TK04-030CJ / TK04-050CJ

- Outer Cap ABS
- Inner Cap PP
- Shive PE
- Inner Jar PP
- Outer Jar SAN

TK04-DT

- Overcap SAN / ABS / PETG
- Actuator PP
- Collor PP
- Dip Tube PE
- Shoulder ABS
- Inner Bottle PET(Blow)
- Outer Bottle SAN

TK04-120BT

- Outer Cap ABS / SAN
- Inner Cap PP
- Reducer PE
- Shoulder ABS
- Inner Bottle PETG(Blow)
- Outer Bottle SAN / PMMA



Item.NO	Capacity	1(mm)	2(mm)
TK04-005CJ	5ml		
TK04-007CJ	7ml		43.5
TK04-010CJ	10ml	40.5	
TK04-015CJ	15ml		43.7
TK04-030CJ	30ml	59.8	67.1
TK04-050CJ	50ml	67.0	76.1
TK04-015DT	15ml		114.5
TK04-020DT	20ml	30.7	
TK04-030DT	30ml		143.3
TK04-050DT	50ml		171.8
TK04-120DT	120ml	44.9	177.6
TK04-120BT	120ml	46.0	178.1

TK05 Lisa Line

MATERIAL

TK05-050CJ

→ Outer Cap	SAN / ABS
→ Inner Cap	PP
→ Shive	PE
→ Inner Jar	PP
→ Outer Jar	SAN

TK05-120BT

→ Outer Cap	SAN / ABS
→ Inner Cap	PP
→ Reducer	PE
→ Shoulder	ABS
→ Inner Bottle	PETG(Blow)
→ Outer Bottle	SAN / PMMA

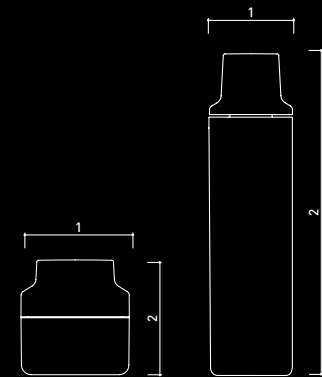

Item.NO	Capacity	1(mm)	2(mm)
TK05-050CJ	50ml	67.0	71.0
TK05-120BT	120ml	46.0	178.0

TK06 Deauville Line

MATERIAL

TK06-010CJ

→ Cap	ABS
→ Jar	ABS

TK06-015CJ-01_02 / TK06-020CJ / TK06-030CJ / TK06-050CJ

→ Outer Cap	SAN / PMMA
→ Inner Cap	ABS
→ Shive	PE
→ Inner Jar	PP
→ Outer Jar	SAN / PMMA

TK06-050DT / TK06-120DT

→ Overcap	PETG / SAN
→ Actuator	PP
→ Collar	PP
→ Dip Tube	PE
→ Inner Bottle	PET(Blow)
→ Outer Bottle	SAN

TK06-030CJF / TK06-050CJF

→ Outer Cap	SAN / PMMA
→ Inner Cap	ABS
→ Shive	LDPE
→ Inner Jar	PP
→ Outer Jar	SAN / PMMA

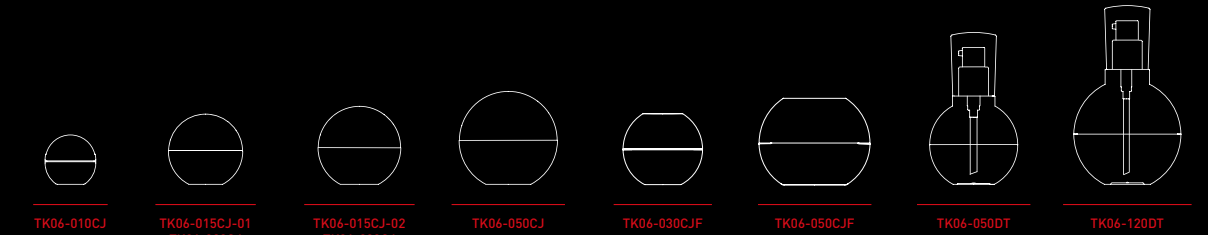
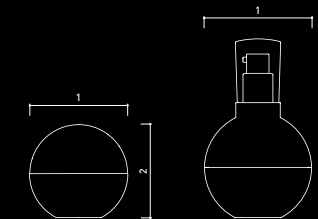

Item.NO	Capacity	1(mm)	2(mm)
TK06-010CJ	10ml	38.2	37.2
TK06-015CJ-01	15ml	60.3	56.8
TK06-015CJ-02		67.0	63.3
TK06-020CJ	20ml	60.3	56.8
TK06-030CJ	30ml	67.0	63.3
TK06-050CJ	50ml	75.0	72.3
TK06-050DT		61.8	106.9
TK06-120DT	120ml	72.0	122.1
TK06-030CJF	30ml	67.1	59.9
TK06-050CJF	50ml	79.9	62.3

TK07 Line

(Boston Jar with Single Cap)



MATERIAL

TK07-005CJ/ 007CJ/ 010CJ/ 015CJ/ 030CJ

- Cap ABS
- Shive PE
- Inner Jar PP
- Outer Jar SAN

TK07-050CJ

- Cap ABS / PETG
- Shive PP
- Inner Jar PP
- Outer Jar SAN / PETG

TK07-100CJ-01 / TK07-150CJ-01 / TK07-200CJ / TK07-220CJ

- Cap ABS
- Shive PP
- Inner Jar PP
- Outer Jar SAN

TK07-150CJ-02

- Cap ABS
- Shive PE
- Inner Jar PP
- Outer Jar SAN

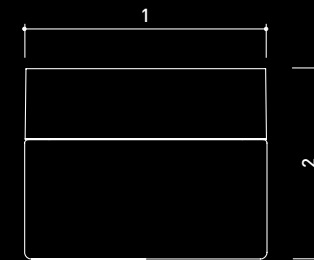

Item.NO	Capacity	1(mm)	2(mm)
TK07-005CJ	5ml		
TK07-007CJ	7ml	40.3	32.0
TK07-010CJ	10ml		
TK07-015CJ	15ml		32.5
TK07-030CJ	30ml	60.0	42.0
TK07-050CJ	50ml	73.0	46.1
TK07-100CJ-01	100ml		46.6
TK07-150CJ-01	150ml		
TK07-150CJ-02	75ml+75ml	95.5	58.0
TK07-200CJ	200ml		
TK07-220CJ	220ml		71.8

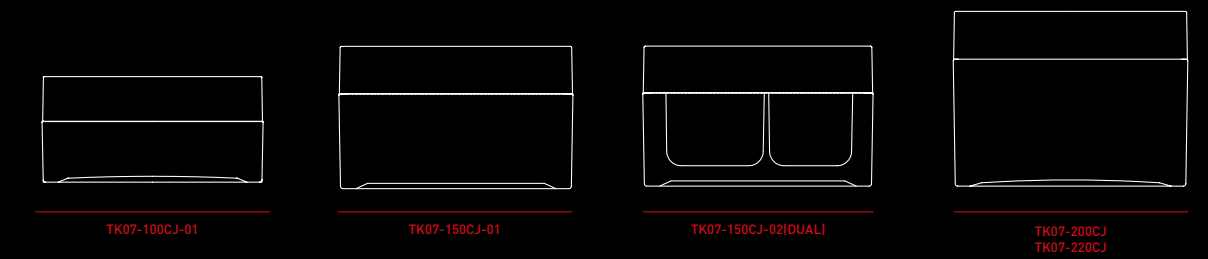
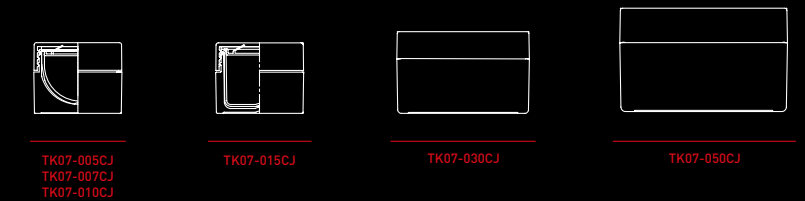

TK08 Line



MATERIAL

TK08-050CJ-01 / 07

- Outer Cap ABS
- Inner Cap PP
- Shive PE
- Inner Jar PP
- Outer Jar SAN

TK08-050CJ-02 / TK08-050CJ-04 / TK08-050CJ-05 / TK08-050CJ-06

- Outer Cap SAN / ABS
- Inner Cap PP
- Shive PE
- Inner Jar PP
- Outer Jar SAN

TK08-050CJ-03

- Cap ABS / PETG
- Shive PP
- Inner Jar PP
- Outer Jar SAN

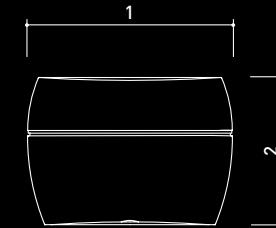

Item.NO	Capacity	1(mm)	2(mm)
TK08-050CJ-01	50ml	71.5	51.4
TK08-050CJ-02		68.8	69.9
TK08-050CJ-03		73.0	46.1
TK08-050CJ-04			53.7
TK08-050CJ-05		66.6	55.9
TK08-050CJ-06			63.8
TK08-050CJ-07		66.2	49.1

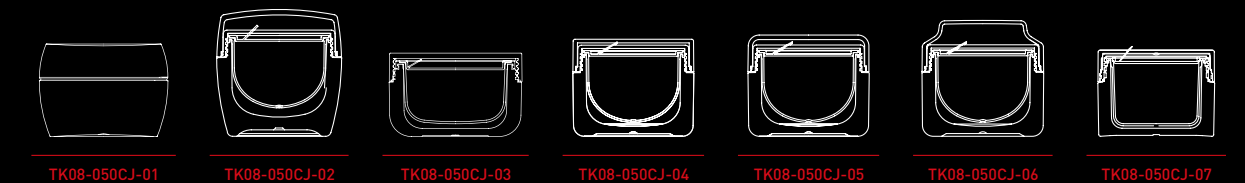

TK09 Line

(PP Jar)



MATERIAL

TK09-005CJ / TK09-300CJ-01 / TK09-300CJ-02

→ Cap PP
→ Jar PP

TK09-050CJ / TK09-100CJ / TK09-200CJ

→ Cap PP
→ Shive PE
→ Inner Jar PP
→ Outer Jar PP

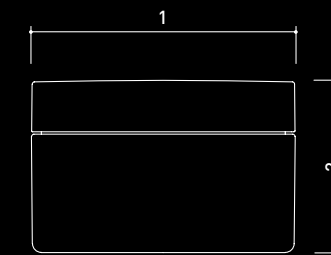

Item.NO	Capacity	1(mm)	2(mm)
TK09-005CJ	5ml	32.7	30.1
TK09-050CJ	50ml	56.7	47.4
TK09-100CJ	100ml	70.8	55.7
TK09-200CJ	200ml	89.6	58.0
TK09-300CJ-01	300ml	92.2	66.1
TK09-300CJ-02			74.0

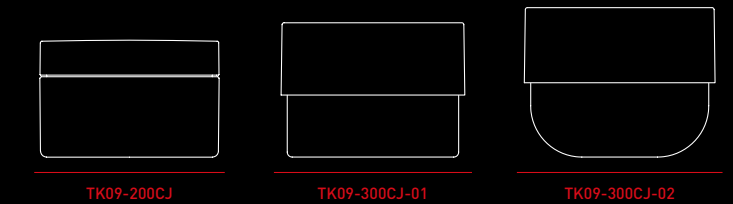
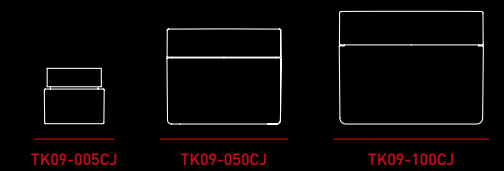

TK10 Line

(Square Jar)

MATERIAL	
TK10-005CJ_007CJ_010CJ/ TK10-010RJ-01	
→ Outer Cap	ABS
→ Inner Cap	POM
→ Shive	PE
→ Inner Jar	PP
→ Outer Jar	PMMA
TK10-007CJ-02	
→ Outer Cap	ABS
→ Inner Cap	POM
→ Shive	PE
→ Jar	PETG
TK10-050CJ-01	
→ Outer Cap	ABS
→ Inner Cap	PP
→ Shive	PE
→ Inner Jar	PP
→ Outer Jar	ABS
→ Base Cover	ABS
TK10-050CJ-02 / TK10-050RJ-01	
→ Outer Cap	ABS
→ Inner Cap	PP
→ Shive	PE
→ Inner Jar	PP
→ Outer Jar	PMMA

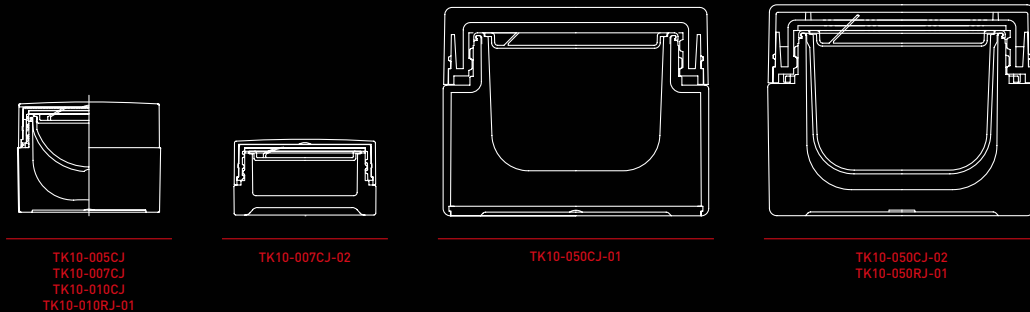
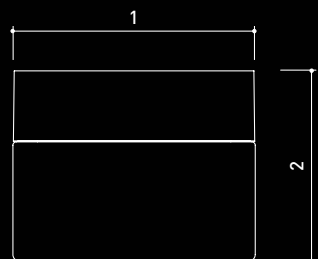

Item.NO	Capacity	1(mm)	2(mm)
TK10-005CJ	5ml		32.8
TK10-007CJ	7ml	42.0	22.5
TK10-007CJ-02			32.8
TK10-010CJ	10ml		56.8
TK10-050CJ-01	50ml	71.5	56.8
TK10-050CJ-02			56.8
TK10-010RJ-01[Refillable]	10ml	42.0	32.8
TK10-050RJ-01[Refillable]	50ml	71.5	56.8

TK11 Line

(Single Jar in PETG)

MATERIAL	
TK11-007CJ/ 010CJ	
→ Cap	ABS
→ Shive	PE
→ Jar	PETG
TK11-020CJ-01/ 02	
→ Cap	ABS
→ Jar	PETG
TK11-050CJ	
→ Cap	PP
→ Shive	PE
→ Jar	PETG
TK11-060CJ-01	
→ Cap	PETG
→ Shive	PE
→ Jar	PETG

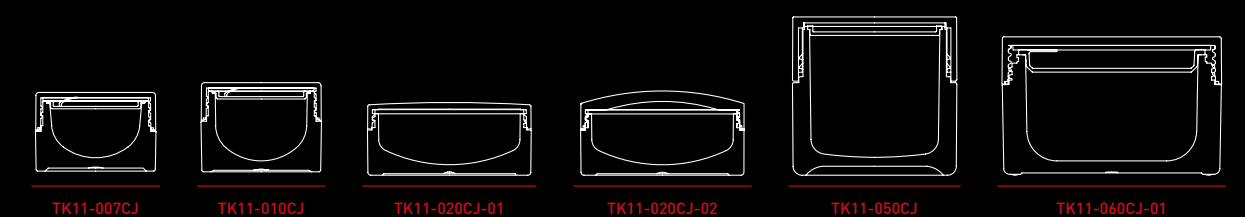
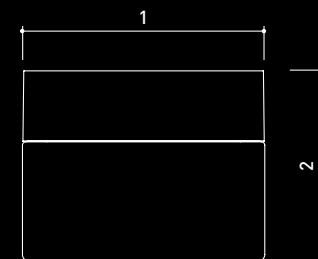

Item.NO	Capacity	1(mm)	2(mm)
TK11-007CJ	7ml		26.5
TK11-010CJ	10ml	40.5	30.0
TK11-020CJ-01			24.3
TK11-020CJ-02	20ml	54.6	28.2
TK11-050CJ	50ml	54.8	53.0
TK11-060CJ-01	60ml	73.3	46.3

TK12 Line (Small Jar)



MATERIAL

01 TK03-005CJ_007CJ_010CJ

→ Outer Cap ABS
→ Inner Cap PP
→ Shive PE
→ Inner Jar PP
→ Outer Jar SAN

02 TK04-005CJ_007CJ_010CJ_015CJ

→ Cap ABS
→ Shive PE
→ Inner Jar PP
→ Outer Jar SAN

03 TK06-010CJ

→ Cap ABS
→ Jar ABS

04, 05 TK07-005CJ/ 007CJ/ 010CJ/ 015CJ

→ Cap ABS
→ Shive PE
→ Inner Jar PP
→ Outer Jar SAN

06 TK09-005CJ

→ Cap PP
→ Jar PP

07 TK10-005CJ_007CJ_010CJ / TK10-010RJ-01

→ Outer Cap ABS
→ Inner Cap POM
→ Shive PE
→ Inner Jar PP
→ Outer Jar PMMA

08 TK12-005CJ_007CJ_010CJ-01

→ Outer Cap ABS
→ Inner Cap POM
→ Shive PE
→ Inner Jar PP
→ Outer Jar PMMA

09 TK12-005CJ_007CJ_010CJ-02

→ Cap ABS
→ Shive PE
→ Inner Jar PP
→ Outer Jar SAN

Item.NO	Capacity	1(mm)	2(mm)
TK03-005CJ	5ml		
TK03-007CJ	7ml	53.5	34.2
TK03-010CJ	10ml		
TK04-005CJ	5ml		
TK04-007CJ	7ml	40.5	43.5
TK04-010CJ	10ml		
TK04-015CJ	15ml		43.7
TK06-010CJ	10ml	38.2	37.2
TK07-005CJ	5ml		
TK07-007CJ	7ml	40.3	32.0
TK07-010CJ	10ml		
TK07-015CJ	15ml		32.5
TK09-005CJ	5ml	33.2	30.7
TK10-005CJ	5ml		
TK10-007CJ	7ml	42.0	32.8
TK10-010CJ	10ml		
TK10-010RJ-01	10ml		
TK12-005CJ-01	5ml		
TK12-007CJ-01	7ml	42.0	32.8
TK12-010CJ-01	10ml		
TK12-005CJ-02	5ml		
TK12-007CJ-02	7ml	43.8	37.5
TK12-010CJ-02	10ml		

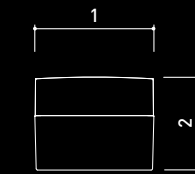

TK12-005CJ-01
TK12-007CJ-01
TK12-010CJ-01

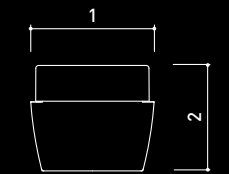

TK12-005CJ-02
TK12-007CJ-02
TK12-010CJ-02

TK13 Line

MATERIAL

TK13-012SJ-01

→ Mirror	Glass
→ Upper Cap	ABS
→ Middle Cap	ABS
→ Jar	PETG

TK13-012SJ-02

→ Mirror	Glass
→ Upper Cap	ABS
→ Inner Jar	PP
→ Middle Cap	ABS
→ Jar	PETG

TK13-012HJ-01

→ Hinged Lid	ABS
→ Mirror	Glass
→ Outer Cap	ABS
→ Inner Cap	PP
→ Jar	PETG
→ Godet	AL

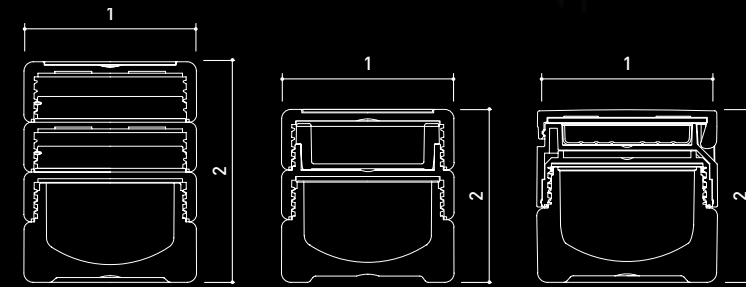

TK13-012SJ-01

TK13-012SJ-02

TK13-012HJ-01

Item.NO	Capacity	1(mm)	2(mm)
TK13-012SJ-01	12ml / 5ml(Stackable)		60.4
TK13-012SJ-02	12ml / 5ml(Inner Jar)	46.8	46.9
TK13-012HJ-01	12ml / 2ml(AL Godet)		42.6

TK14 Line (Air Tight Refillable Jar)

MATERIAL

TK14-030RJ-01_02

→ Outer Cap	ABS
→ Inner Cap	PP
→ Refill Inner Jar	PP
→ Platform	PP
→ Outer Jar	SAN
→ Refill Case	PP

TK14-050RJ

→ Outer Cap	ABS
→ Inner Cap	PP
→ Cover Ring	PP
→ Refill Inner Jar	PP
→ Platform	PP
→ Outer Jar	SAN

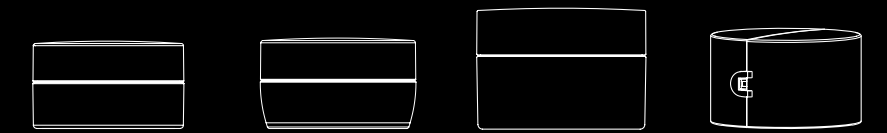
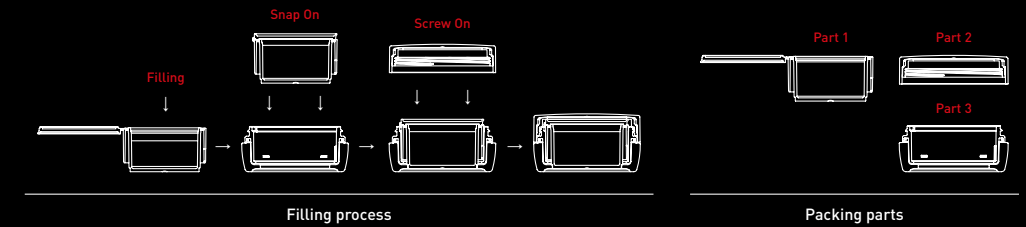

TK14-030RJ-01

TK14-030RJ-02

TK14-050RJ

Refill Case
(30ml Only)

Item.NO	Capacity	1(mm)	2(mm)
TK14-030RJ-01			
TK14-030RJ-02	30ml	67.5	39.5
TK14-050RJ	50ml	73.8	52.8

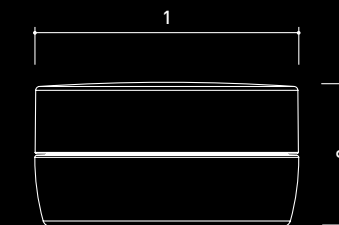

TK15 Line

(Net Sifter Jar for Beads)

MATERIAL

TK15-025NJ-01

→ Cap	ABS
→ Sifter	PP
→ Net	Nylon
→ Rubber Pad	HNBR
→ Inner Jar	PP
→ Outer Jar	SAN

TK15-025NJ-02

→ Cap	ABS
→ Sifter	PP
→ Net	Nylon
→ Inner Jar	PP
→ Outer Jar	SAN

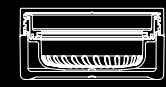
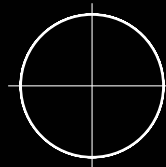

TK15-025NJ-01
TK15-025NJ-02

Item.NO	Capacity	1(mm)	2(mm)
TK15-025NJ-01	25g	69.8	34.7
TK15-025NJ-02			

TK16 Line

(Single Bead Dispensing Jar)

MATERIAL

TK16-050BJ

→ Overcap	ABS
→ Packing Holder	PP
→ Packing	NBR
→ Shoulder	PP
→ Screw Housing	PP
→ Screw	PP
→ Inner Jar	PP
→ Outer Jar	SAN

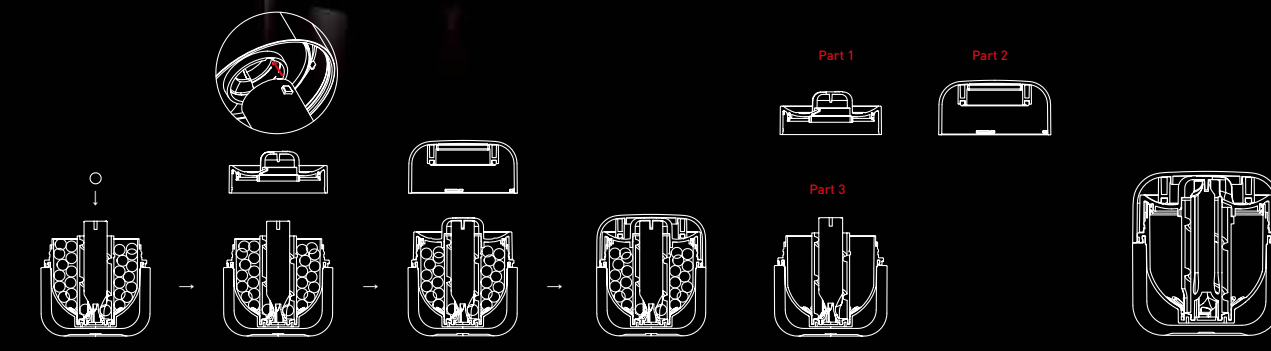

Filling process

Packing parts

Item.NO	Capacity	1(mm)	2(mm)
TK16-050BJ	50g	73.4	81.6

TK17 Line

MATERIAL

TK17-045DT

- Overcap PETG
- Actuator PP
- Collar ABS
- Shoulder PETG
- Dip tube PE
- Inner Bottle PETG (BLOW)
- Outer Bottle SAN

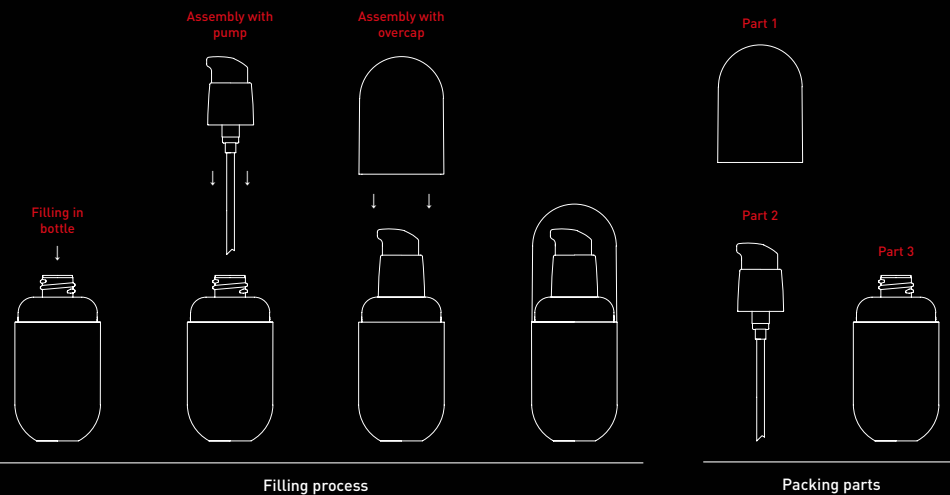
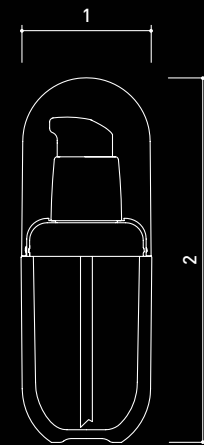

Item.NO	Capacity	1(mm)	2(mm)
TK17-045DT	45ml	44.4	123.8

TK20 Line

MATERIAL

TK20-030CJ-01 / TK20-050CJ-01

- Cap PP
- Shive LDPE
- Jar Glass

TK20-100BT-01 / TK20-150BT-03

- Outer Cap ABS
- Inner Cap PP
- Reducer LDPE
- Bottle Glass

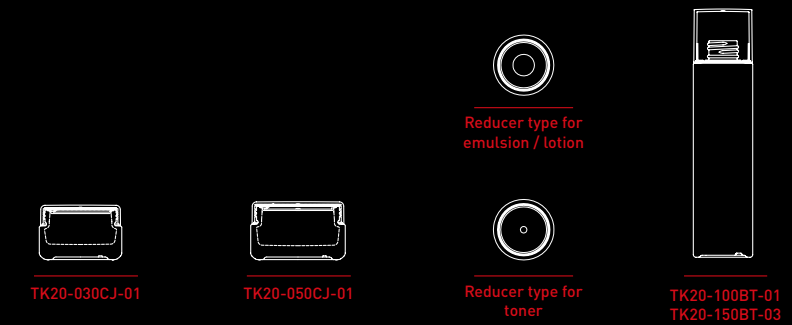
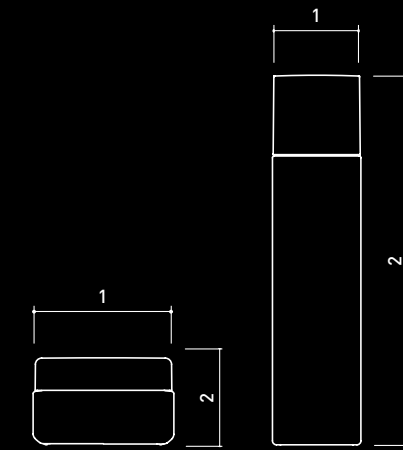

Item.NO	Capacity	1(mm)	2(mm)
TK20-030CJ-01	30ml	57.5	38.2
TK20-050CJ-01	50ml	65.9	40.7
TK20-100BT-01	100ml	43.6	141.0
TK20-150BT-03	150ml	43.6	188.0

TK21 Line (Nude Dropper)



MATERIAL

TK21-006DR-01/ 02

- Cap PETG
- Bottle BELLPET
- Actuator ELASTOMER(01) / NBR(02)
- Base PCTA

TK21-006DR-03/ 04

- Cap PP
- Bottle PP
- Actuator ELASTOMER(03) / NBR(04)
- Base PP

TK21-007DR-02

- Cap PETG
- Bottle BELLPET
- Teat ELASTOMER
- Base PCTA

TK21-020DR/ 020DRAL

- Cap PETG
- Bottle BELLPET
- Bottle Cover AL
- Actuator LDPE
- Base PCTA

TK21-020DRPL

- Plaque PMMA
- Cap PETG
- Bottle BELLPET
- Actuator LDPE
- Base PCTA

TK21-015DR/ 030DR

- Outer Cap ABS
- Inner Cap PP
- Bottle BELLPET
- Actuator (015DR) ELASTOMER/ NBR (030DR) NBR
- Base PETG

TK21-015MX

- Outer Cap ABS
- Inner Cap PP
- Bottle BELLPET
- Actuator ELASTOMER/ NBR
- Base PETG
- Powder Cap LDPE
- Powder Actuator PP

Item.NO	Capacity	1(mm)	2(mm)
TK21-006DR-01/ 02/ 03/ 04	6ml	21.1	65.5
TK21-007DR-02	7ml	21.2	85.5
TK21-015DR	15ml	29.0	87.9
TK21-020DR	20ml	26.6	90.9
TK21-020DRPL	20ml	26.6	92.7
TK21-020DRAL	20ml	28.5	93.5
TK21-030DR	30ml	29.7	113.0
TK21-015MX	15ml + 3ml	29.0	102.3

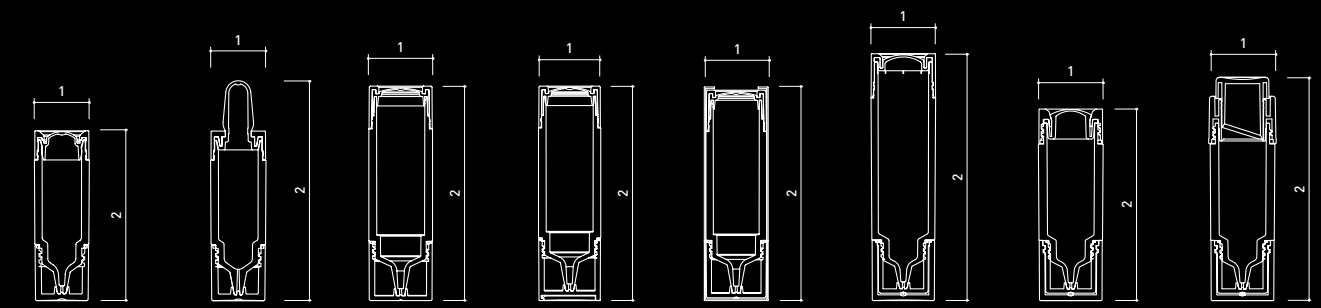

TK21-006DR

TK21-007DR-02

TK21-020DR

TK21-020DRPL

TK21-020DRAL

TK21-030DR

TK21-015DR

TK21-015MX
with Powder Cap

TK31 Line

(Loose Powder Jar)

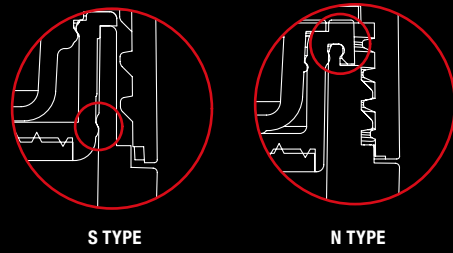

MATERIAL

TK31-LP

→ Cap	ABS
→ Sifter	PP
→ Sifter Label	PET / PP
→ Jar	SAN

TK31-LPT

→ Cap	ABS
→ Sifter	PP
→ Jar	SAN

TK31-LFS

→ Cap	ABS
→ Living Hinge Sifter	PP
→ Jar(10g)	PETG
→ Jar(20g)	SAN

TK31-LPN

→ Cap	ABS
→ Sifter	PP
→ Jar	PETG

TK31-LFN

→ Cap	ABS
→ Living Hinge Sifter	PP
→ Jar	PETG

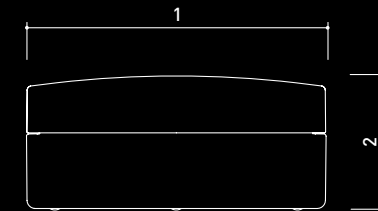

Item.NO	Capacity	1(mm)	2(mm)
TK31-006LP-01	6g (powder)	54.6	24.4
TK31-006LP-02			28.5
TK31-010LP-01	10g (powder)	73.9	24.5
TK31-020LP	20g (powder)		33.4
TK31-035LP-01	35g (powder)	86.6	48.6
TK31-035LP-02			43.0
TK31-035LP-03			48.6
TK31-035LP-04			43.0
TK31-003LPT-01	3g (powder)	54.6	24.3
TK31-003LPT-02			25.8
TK31-010LFS-01	10g (powder)	70.5	34.4
TK31-010LFS-02			30.4
TK31-020LFS	20g (powder)		35.0
TK31-020LPN-01	20g (powder)	73.0	35.1
TK31-020LFN-01			

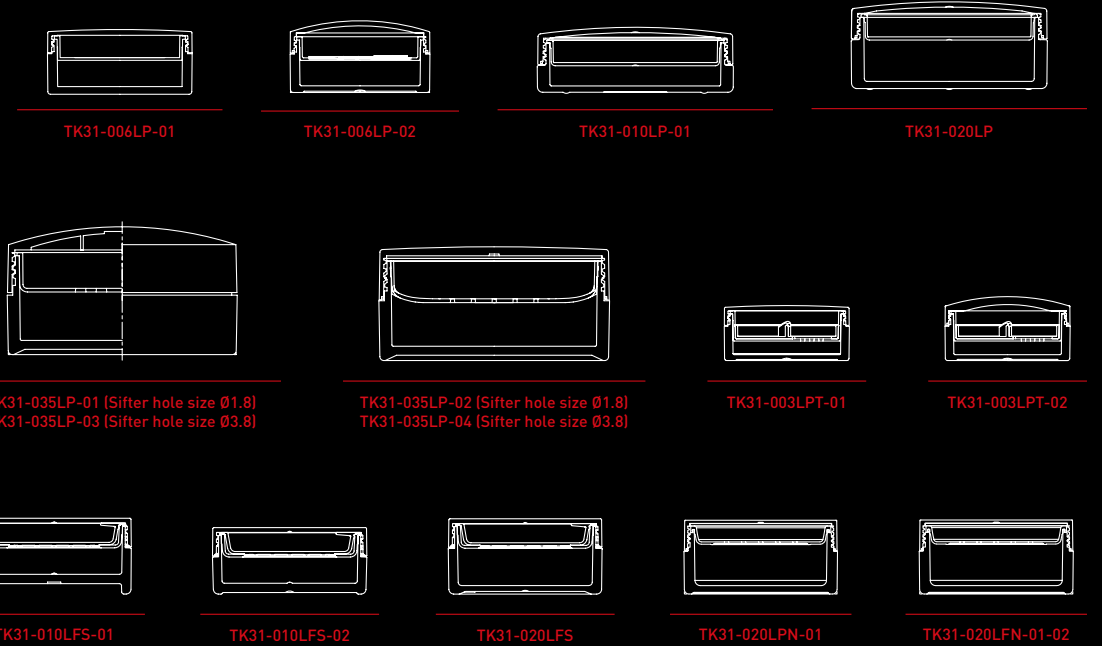

TK32 Line

(Loose Powder Jar with Net Sifter)

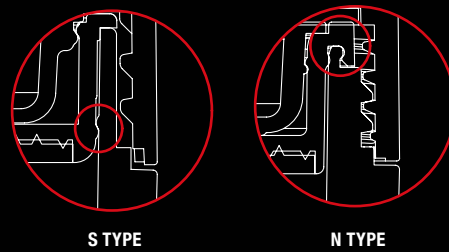

MATERIAL

TK32-NP / TK32-NPS

- Cap ABS
- Net Sifter PP+Nylon
- Sifter Label PP / PET
- Jar(3g/7g/20g/30g) SAN
- Jar(10g) PETG

TK32-NF / TK32-NFS

- Cap ABS
- Flapper PP
- Net Sifter PP+Nylon
- Sifter Label PP / PET
- Jar(10g) PETG
- Jar(20g / 30g) SAN

TK32-NFN

- Cap ABS
- Flapper PP
- Net Sifter PP+Nylon
- Sifter Label PP / PET
- Jar(10g) PETG

TK32-NC

- Cap ABS
- Puff Case PP
- Net Sifter PP+Nylon
- Sifter Label PP / PET
- Jar(30g) SAN

TK32-LFS

- Cap ABS
- Living Hinge Net Sifter PP+Nylon
- Sifter Label PP / PET
- Jar(10g) PETG
- Jar(20g) SAN

TK32-LFN

- Cap ABS
- Living Hinge Net Sifter PP+Nylon
- Sifter Label PP / PET
- Jar(10g / 20g) PETG

TK32-RC

- Compact ABS
- Living Hinge Net Sifter PP+Nylon
- Refill Inner Jar PETG

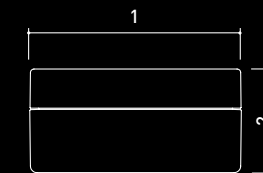

Item.NO	Capacity	1(mm)	2(mm)
TK32-003NP	3g (powder)	45.0	21.0
TK32-007NP	7g (powder)	55.0	24.0
TK32-010NPS-02	10g (powder)	70.5	30.3
TK32-020NPS	20g (powder)	70.5	34.5
TK32-030NP-01	30g (powder)	95.0	46.2
TK32-030NP-02		70.5	48.3
TK32-030NC-01		95.0	46.2
TK32-030NF-02		70.5	48.3
TK32-010NFS-01	10g (powder)		34.5
TK32-010NFS-02		70.5	30.3
TK32-020NFS	20g (powder)		34.5
TK32-010NFN-01		70.0	30.4
TK32-010LFS-01	10g (powder)		34.5
TK32-010LFS-02		70.5	30.3
TK32-020LFS	20g (powder)		34.5
TK32-010LFN-01	10g (powder)	70.0	30.4
TK32-020LFN-01	20g (powder)	72.6	35.1
TK32-005RC-01	5g (powder)	80.2	23.7
TK32-010RC-01	10g (powder)	80.5	35.2

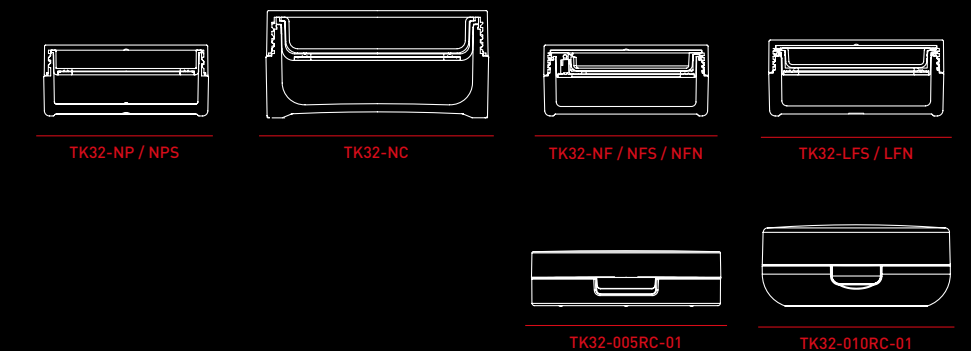

TK33 Line

(Loose Powder Jar with Hinged Cap)



MATERIAL

TK33-010LP / TK33-020LP-01 / TK33-020LP-02

- Lid ABS
- Mirror Glass
- Sifter ABS
- Sifter Label PP / PET
- Jar SAN

TK33-010NP / TK33-020NP

- Lid ABS
- Mirror Glass
- Sifter ABS
- Sifter Label PP / PET
- Net Nylon
- Jar SAN

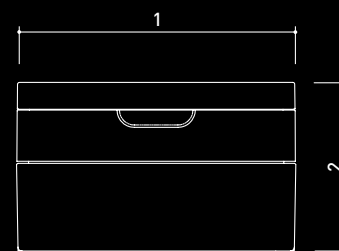

Item.NO	Capacity	1(mm)	2(mm)
TK33-010LP	10g (powder)		34.8
TK33-020LP-01	20g (powder)		42.3
TK33-020LP-02	20g (powder)	69.5	42.7
TK33-010NP	10g (powder)		34.8
TK33-020NP	20g (powder)		42.3

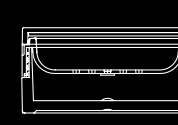

TK33-010LP

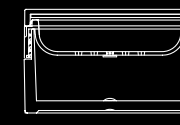

TK33-020LP-01

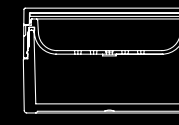

TK33-020LP-02
(SNAP-ON TYPE)

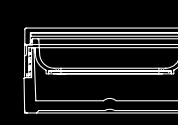

TK33-010NP

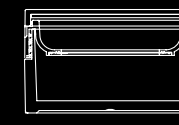

TK33-020NP

TK34 Line (Cleansing Powder Bottle)

MATERIAL	
TK34-PB	
→ Cap	PP
→ Bottle	HDPE(Blow)

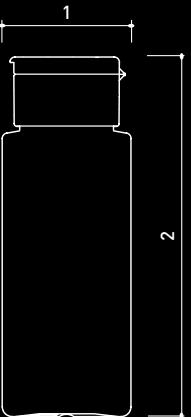

Item.NO	Capacity	1(mm)	2(mm)
TK34-040PB-01	40g	44.0	115.5
TK34-050PB	50g	46.6	130.5
TK34-080PB-01	80g	49.0	142.5

TK35 Line (Deauville Loose Powder Jar)

MATERIAL	
TK35-003LP	
→ Cap	ABS
→ Sifter	PE
→ Jar	ABS / SAN
TK35-010LP / TK35-025LP	
→ Cap	ABS
→ Sifter	PE
→ Jar	ABS / SAN
TK35-007LPT	
→ Cap	ABS / SAN
→ Sifter	PP
→ Jar	ABS / SAN

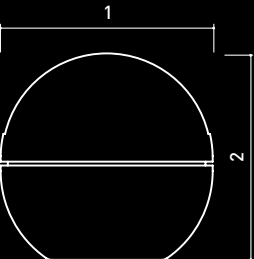

Item.NO	Capacity	1(mm)	2(mm)
TK35-003LP	3g (Powder)	38.2	37.4
TK35-010LP	10g (Powder)	55.6	50.6
TK35-007LPT	7g (Powder)	73.0	66.8
TK35-025LP	25g (Powder)		

TK36 Line (Cylindrical Loose Powder)

MATERIAL

TK36-LP

- Cap ABS
- Sifter PE
- Sifter Label PP / PE
- Jar SAN

TK36-LPF

- Cap SAN
- Puff Flocking
- Shoulder ABS
- Shive PE
- Jar SAN

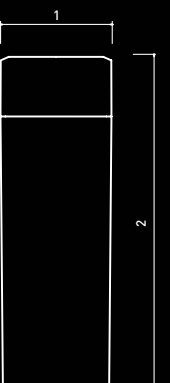



Item.NO	Capacity	1(mm)	2(mm)
TK36-002LP	2.5g (Powder)	27.0	28.5
TK36-005LP	5g (Powder)		54.4
TK36-007LP	7g (Powder)		74.1
TK36-002LPF	2.5g (Powder)		45.9
TK36-005LPF	5g (Powder)		73.8
TK36-007LPF	7g (Powder)		93.7

TK37 Line (Retractable Cheek Stamp)

MATERIAL

TK37-002BS-01

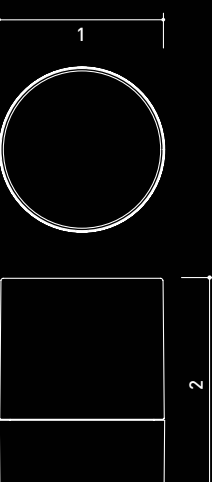
- Cap ABS
- Godet AL
- Sponge NBR
- Sponge Holder ABS
- Base ABS



Item.NO	Capacity	1(mm)	2(mm)
TK37-002BS-01	2ml	35.0	45.6

TK41 Line

(Round Cushion Compact)



MATERIAL

TK41-015AC-01_07_13_19 /
TK41-012AC-01_02_03_04

→ Compact ABS
→ 12g / 15g Refill PP
→ Cover Ring PP
→ Net Ring PP+NYLON

TK41-015AC-25_31 / TK41-012AC-05_06

→ Plaque SAN
→ Compact ABS
→ 12g / 15g Refill PP
→ Cover Ring PP
→ Net Ring PP+NYLON

TK41-015AT-01_03_05_07 /
TK41-012AT-01_02_03_04

→ Compact ABS
→ 12g AT Type Refill PP+LDPE
→ 15g AT Type Refill PP+LDPE / PBT+LDPE
→ Cover Ring PP
→ Net Ring PP+NYLON

TK41-015AT-21_23 / TK41-012AT-05_06

→ Plaque SAN
→ Compact ABS
→ 12g AT Type Refill PP+LDPE
→ 15g AT Type Refill PP+LDPE / PBT+LDPE
→ Cover Ring PP
→ Net Ring PP+NYLON

TK41-012BC-01_02

→ Plaque SAN
→ Slim Compact ABS
→ 12g Refill PP
→ Godet AL

TK41-012AT-07_08

→ Plaque SAN
→ Slim Compact ABS
→ 12g AT Type Refill PP+LDPE
→ Cover Ring PP

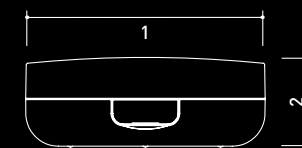

Item.NO	Capacity	1(mm)	2(mm)
TK41-015AC-01		75.8	28.5
TK41-015AC-07			
TK41-015AC-13	15g	77.1	28.4
TK41-015AC-19			
TK41-015AC-25		76.0	32.7
TK41-015AC-31			
TK41-012AC-01	12g		
TK41-015AT-01	15g	75.8	28.5
TK41-012AT-01			
TK41-012BC-01			26.3
TK41-012BC-02	12g	78.0	28.8
TK41-012AT-07			26.3
TK41-012AT-08			28.8

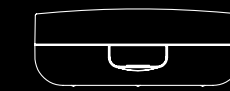

TK41-015AC-01

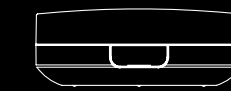

TK41-015AC-07



TK41-015AC-13

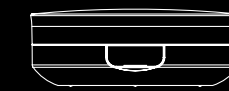

TK41-015AC-19



TK41-015AC-25

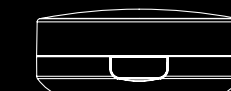

TK41-015AC-31

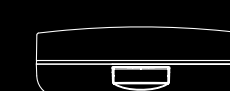

TK41-012BC-01
TK41-012AT-07



TK41-012BC-02
TK41-012AT-08

TK42 Line (Square Cushion Compact)

MATERIAL	
TK42-015AC-01 / TK42-015SC-01	
→ Outer Lid	ABS
→ Mirror	Glass
→ Platform	ABS
→ Outer Base	ABS
→ Button	PCTA
→ Refill Inner Lid	PP
→ Refill Inner Base	PP
→ Cover Ring	PP
TK42-015AC-07	
→ Plaque	SAN
→ Outer Lid	ABS
→ Mirror	Glass
→ Platform	ABS
→ Outer Base	ABS
→ Button	PCTA
→ Refill Inner Lid	PP
→ Refill Inner Base	PP
→ Cover Ring	PP
TK42-012AC-01	
→ Outer Lid	ABS
→ Mirror	Glass
→ Platform	ABS
→ Outer Base	ABS
→ Button	PCTA
→ Refill Inner Lid	PP
→ Refill Inner Base	PP
→ Refill Inner Disc	PP
→ Cover Ring	PP
TK42-015AT-01 / TK42-012AT-01	
→ Outer Lid	ABS
→ Mirror	Glass
→ Platform	ABS
→ Outer Base	ABS
→ Button	PCTA
→ Refill Inner Lid	PP
→ Refill Inner Base	PP
→ Refill Inserted Ring	LDPE
→ Refill Inner Disc	PP

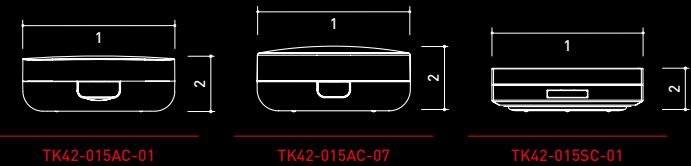

Item.NO	Capacity	1(mm)	2(mm)
TK42-015AC-01	15g	75.8	28.5
TK42-015AC-07		76.0	32.6
TK42-012AC-01	12g	75.8	28.5
TK42-015AT-01	15g	75.8	28.5
TK42-012AT-01	12g		
TK42-015SC-01	15g	74.7	21.0

TK43 Line (Mini Cushion Compact)

MATERIAL	
TK43-005MC-01	
→ Outer Lid	ABS
→ Mirror	Glass
→ Platform	ABS
→ Outer Base	ABS
→ Refill Inner Lid	PP
→ Refill Inner Base	PP
→ Cover Ring	PP
TK43-005MC-02	
→ Outer Lid	ABS
→ Mirror	Glass
→ Platform	ABS
→ Outer Base	ABS
→ Refill Inner Lid	PP
→ Refill Inner Base	PP
→ Net Ring	PP + Nylon

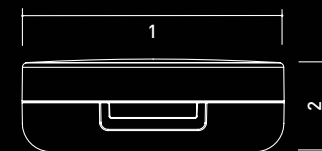

Item.NO	Capacity	1(mm)	2(mm)
TK43-005MC-01	5g	54.8	19.8
TK43-005MC-02			

TK45 Line

(2 in 1 Cushion Compact)

MATERIAL

TK45-012DD

- Plaque SAN
- Outer Lid ABS
- Mirror Glass
- Platform ABS
- Outer Base ABS
- Refill Inner Jar PP
- Refill Inserted Ring LDPE
- Button PCTA
- Cover Ring PP
- Godet AL
- Drawer ABS
- Drawer Base ABS
- Axis Pin POM

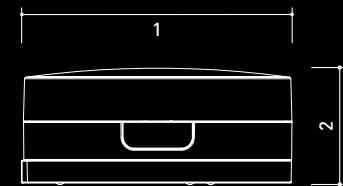

Item.NO	Capacity	1(mm)	2(mm)
TK45-012DD-01	12g (Refill) / 8g (Drawer)	79.4	34.8
TK45-012DD-02	12g (Refill) / 4g each (Drawer)		

TK47 Line

(Large Compact)

MATERIAL

TK47-100LC-01 / TK47-100LC-06 / TK47-100LC-07

- Lid ABS / PMMA
- Mirror Glass
- Platform ABS
- Base ABS

TK47-100LC-02

- Lid ABS
- Mirror Glass
- Base ABS

TK47-100LC-03

- Lid Cover SAN
- Lid ABS
- Mirror Glass
- Platform ABS
- Base ABS

TK47-100LC-04

- Lid ABS
- Mirror Glass
- Platform ABS
- Base ABS

TK47-100LC-05

- Lid ABS
- Platform ABS
- Base ABS

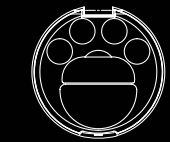
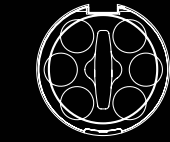

Item.NO	Capacity	1(mm)	2(mm)
TK47-100LC-01	Ø80mm Godet	100.0	14.5
TK47-100LC-02			
TK47-100LC-03			
TK47-100LC-04			
TK47-100LC-05	Ø24mm Godet		31.9
TK47-100LC-06			14.5
TK47-100LC-07			

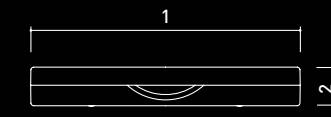

TK48 Line

(Square Compact)



MATERIAL

TK48-066SC-01 / TK48-066SC-02 / TK48-066SC-03 / TK48-066SC-04

- Lid ABS
- Plaque ABS
- Mirror Glass
- Flapper PC
- Platform ABS
- Base ABS
- Button PC

TK48-056SC

- Lid ABS
- Mirror Glass
- Plaque ABS / SAN
- Platform ABS
- Base ABS

TK48-037SC

- Lid ABS
- Mirror Glass
- Plaque ABS
- Base ABS

TK48-064SC / TK48-052SC

- Upper Lid ABS
- Godet AL
- Middle Lid ABS
- Mirror Glass
- Platform ABS
- Base ABS

TK48-044SC-01 / TK48-044SC-02

- Plaque SAN
- Lid ABS
- Mirror Glass
- Platform ABS
- Base ABS
- Godet AL

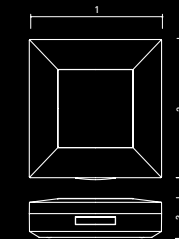

Item.NO	Capacity	1(mm)	2(mm)	3(mm)
TK48-066SC-01				19.7
TK48-066SC-02		66.7	69.7	
TK48-066SC-03				16.2
TK48-066SC-04				
TK48-056SC		56.2	56.2	
TK48-037SC		37.0	37.0	11.3
TK48-064SC	12g	64.0	64.0	20.0
TK48-052SC	9g	58.6	58.6	18.8
TK48-044SC-01	18g	60.0	81.5	15.0
TK48-044SC-02	8g+8g			

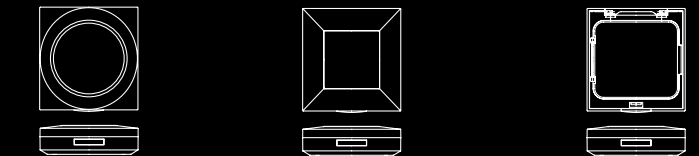

TK48-066SC-01 / TK48-066SC-02

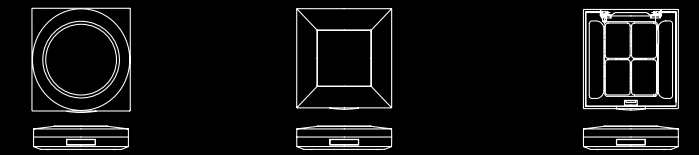

TK48-066SC-03 / TK48-066SC-04

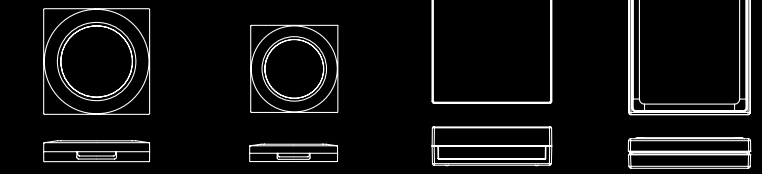

TK48-056SC

TK48-037SC

TK48-064SC
TK48-052SC

TK48-044SC

TK49 Line (Round Compact)

MATERIAL

TK49-075RC

- Lid ABS
- Mirror Glass
- Base ABS

TK49-084RC

- Lid ABS
- Mirror Glass
- Flapper PC
- Platform ABS
- Base ABS
- Button PCTA

TK49-008RC-01

- Lid ABS
- Press Shive PET
- Base ABS
- Godet AL

TK49-010RC-01_02_03_04

- Lid ABS
- Platform ABS
- Base ABS
- Button PCTA
- Flapper SAN
- Godet AL

TK49-010RC-05_06

- Plaque SAN
- Lid ABS
- Platform ABS
- Base ABS
- Button PCTA
- Flapper PC
- Godet AL

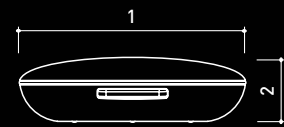

TK49-075RC



TK49-084RC



TK49-008RC-01



TK49-010RC

Item.NO	Capacity	1(mm)	2(mm)
TK49-075RC		75.0	18.5
TK49-084RC	∅59mm Godet	84.4	24.0
TK49-008RC-01	8g	65.0	21.3
TK49-010RC-01_02		75.8	28.5
TK49-010RC-03_04	10g	77.1	28.4
TK49-010RC-05_06		76.0	32.7

TK50 Line (Swivel Palette & Spin Pot)

MATERIAL

TK50-004PL

- Upper Lid ABS
- Upper Lid Cover ABS
- Platform ABS
- Platform Base ABS
- Base ABS
- Base Cover ABS
- Hinge POM
- Magnet Magnet

TK50-435SP_415SP

- Outer Cap ABS
- Inner Cap PP
- Drawer ABS
- Jar ABS
- Base ABS
- Godet AL



TK50-004PL

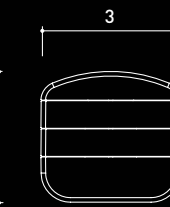

TK50-435SP

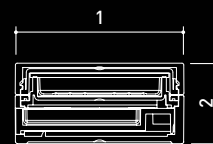

TK50-415SP

Item.NO	Capacity	1(mm)	2(mm)	3(mm)
TK50-004PL		122.0	35.6	38.0
TK50-435SP	4g / 3.5g (Drawer)	45.8	22.0	-
TK50-415SP	4g / 1.5g each (Drawer)			

TK51 Line

(Lipgloss & Concealer)

MATERIAL

TK51-002LG

- Outer Cap ABS
- Inner Cap PP
- Tip FLOCKING SPONGE
- Wiper PE
- Bottle SAN / PETG

TK51-006LG-01

- Overcap PETG
- Brush Cover PETG
- Brush Holder ABS
- Bottle SAN / PETG
- Inner Cap PP
- Outer Cap ABS
- Shoulder ABS
- Brush Nylon
- Tip FLOCKING SPONGE
- Wiper PE

TK51-006LG-02

- Overcap PETG
- Sponge Holder ABS
- Bottle SAN / PETG
- Inner Cap PP
- Outer Cap ABS
- Shoulder ABS
- Sponge NBR
- Tip FLOCKING SPONGE
- Wiper PE

TK51-006LG-03 / TK51-008LG

- Outer Cap ABS
- Inner Cap PP
- Tip FLOCKING SPONGE
- Wiper PE
- Shoulder ABS
- Bottle SAN

TK51-005LGS-01, 02, 03, 04, 05, 06

- Outer cap ABS
- Inner cap PETG
- Tip FLOCKING SPONGE
- Wiper PE
- Bottle PETG



TK51-002LG TK51-006LG-01 TK51-006LG-02 TK51-006LG-03 TK51-008LG TK51-005LGS-01, 02, 05 [Sharp edge] TK51-005LGS-03, 04, 06 [Round edge]

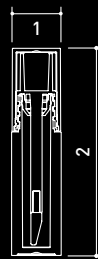

Item.NO	Capacity	1(mm)	2(mm)
TK51-002LG	2ml	27.5	70.0
TK51-006LG-01			
TK51-006LG-02	6ml	19.2	129.7
TK51-006LG-03		19.0	98.1
TK51-008LG	8ml	17.5	100.4
TK51-005LGS-01, 02, 03, 04, 05, 06	5ml	21.0	87.2

TK52 Line

(Stick)

MATERIAL

TK52-010ST-01/ 02

- Overcap PP
- Inner Bottle PP
- Outer Bottle PP
- Base PP
- Brush Nylon
- BrushHolder ABS

TK52-020ST-01

- Overcap PP
- Inner Cap PP
- Inner Bottle PP
- Outer Bottle PP
- Base PP
- Applicator Silicon

TK52-020ST-02

- Overcap PP
- Inner Cap PP
- Inner Bottle PP
- Outer Bottle PP
- Base PP

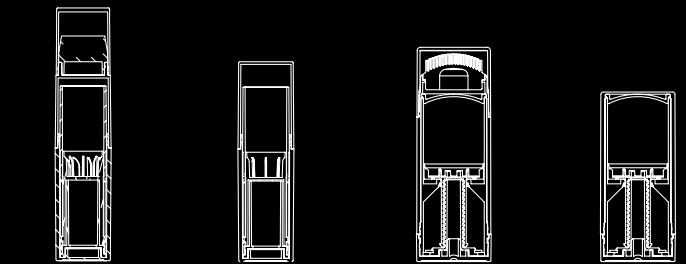
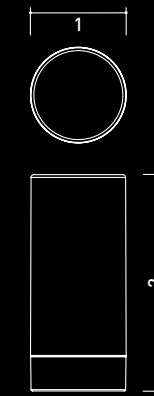

TK52-010ST-01 TK52-010ST-02 TK52-020ST-01 TK52-020ST-02

Item.NO	Capacity	1(mm)	2(mm)
TK52-010ST-01	10ml	25.8	116.0
TK52-010ST-02	10ml	25.8	86.3
TK52-020ST-01		33.8	98.3
TK52-020ST-02	20ml	34.0	77.9

TK53 Line (Square Lipstick)

MATERIAL

TK53-003SL

- Cap ABS
- Shoulder ABS
- Base ABS
- Dish PETG
- Dish Holder ABS

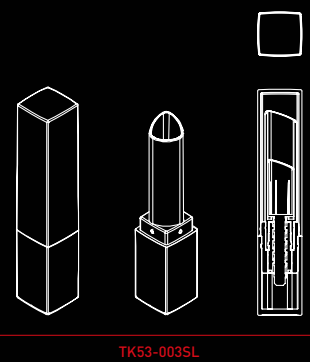

TK53-003SL

Item.NO	Capacity	1(mm)	2(mm)
TK53-003SL	3g	16.8	86.1

TK54 Line (Foundation with Applicator)

MATERIAL

TK54-003FS / TK54-005FS

- Cap PETG
- Wad LDPE
- Spatula PP
- Bottle Glass

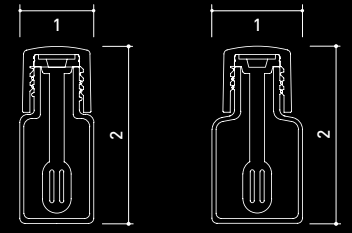

TK54-003FS

TK54-005FS

Item.NO	Capacity	1(mm)	2(mm)
TK54-003FS	3ml	18.0	43.0
TK54-005FS	5ml	22.0	43.0

TK55 Line (Spatula)

MATERIAL

TK55-000SP-01

→ Spatula PP
→ Handle PP

TK55-000SP-02_03_04_05_06

→ Spatula PP / PETG
→ Handle PP / PETG

TK55-000SP-07

→ Spatula PETG
→ Handle PETG

TK55-000SP-08

→ Spatula PP
→ Handle ABS

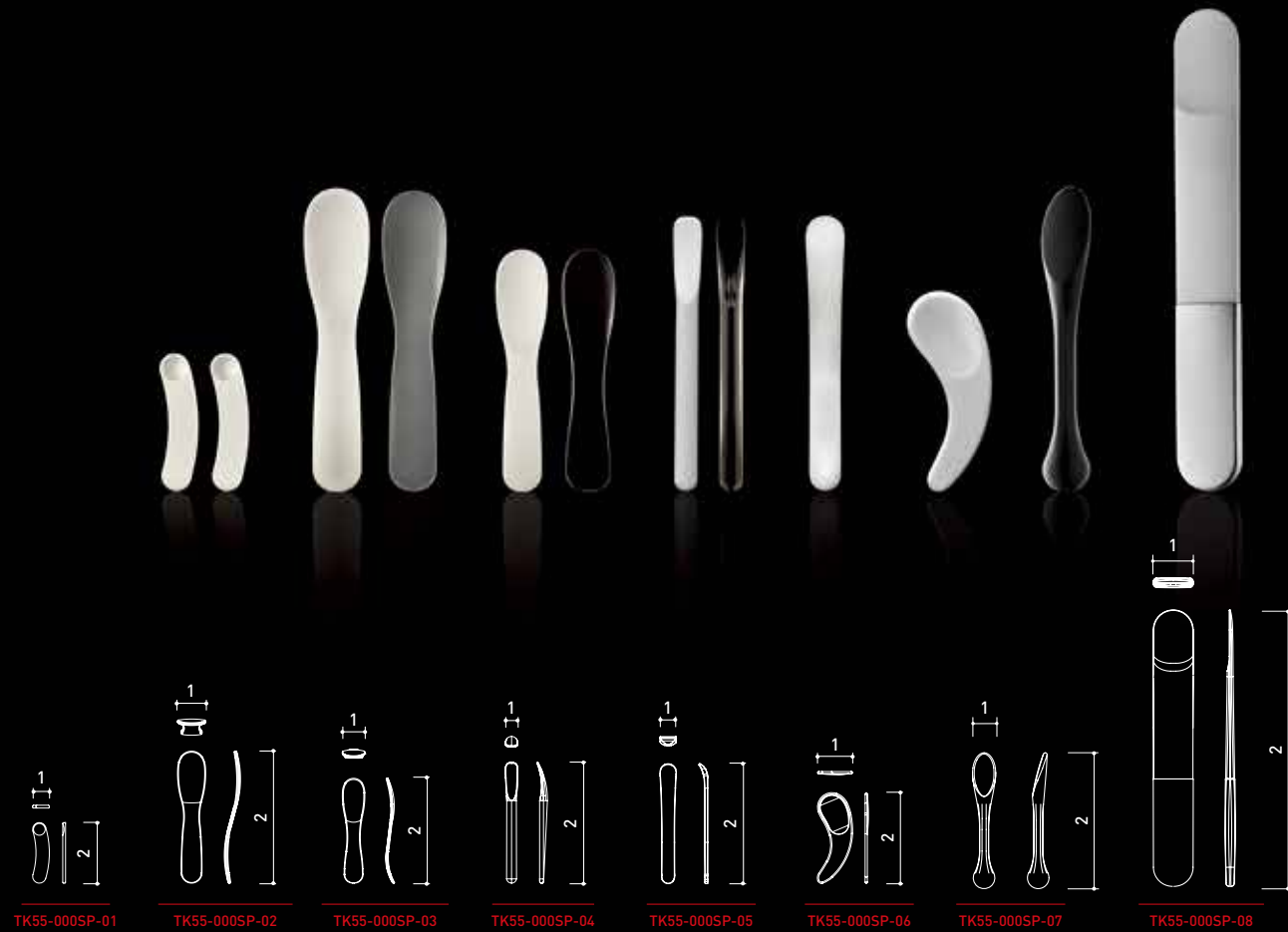

Item.NO	1(mm)	2(mm)
TK55-000SP-01	10.0	36.0
TK55-000SP-02	16.8	78.4
TK55-000SP-03	13.5	62.3
TK55-000SP-04	7.5	71.6
TK55-000SP-05	10.0	71.3
TK55-000SP-06	20.8	53.5
TK55-000SP-07	12.5	79.0
TK55-000SP-08	24.0	166.0

TK56 Line (Massager)

MATERIAL

TK56-084MS-01

→ Head ZINC
→ Handle PETG

TK56-084MS-02

→ Head PETG
→ Handle PETG

TK56-056MS-01

→ Spatula ZINC
→ Handle ZINC

TK56-067MS-01

→ Head ZINC
→ Handle PP / PETG



Item.NO	1(mm)	2(mm)
TK56-084MS-01	13.9	84.9
TK56-084MS-02	13.6	84.9
TK56-056MS-01	9.9	56.0
TK56-067MS-01	11.7	67.0

Auto Priming Dropper

MATERIAL

TK-AD15G / TK-AD20G / TK-AD30G

- Outer Cap ABS
- Inner Cap PP
- Button ABS
- Pipette Glass
- Bottle Glass
- Wiper PE

TK-AD15GA / TK-AD30GA

- Outer Cap ABS
- Inner Cap PP
- Button ABS
- Pipette Glass
- Inner Bottle Glass
- Bottle Cover AL
- Base ABS
- Wiper PE

TK-AD15B / TK-AD30B

- Outer Cap ABS
- Inner Cap PP
- Button ABS
- Pipette Glass
- Bottle PETG
- Wiper PE

TK-AD15BA / TK-AD30BA

- Outer Cap ABS
- Inner Cap PP
- Button ABS
- Pipette Glass
- Inner Bottle PETG
- Bottle Cover AL
- Base ABS
- Wiper PE

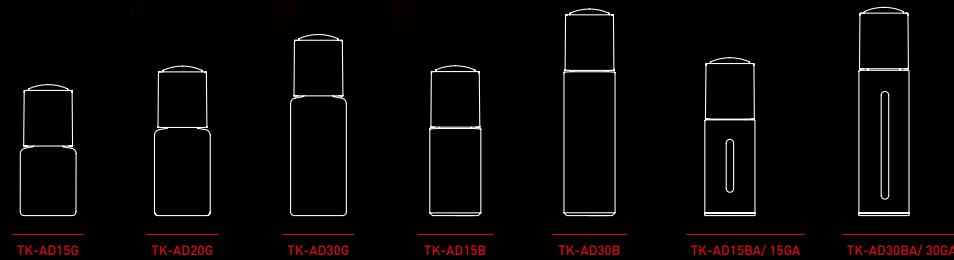
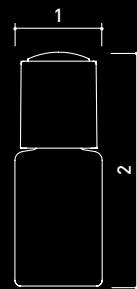

Ref.NO	Item.NO	Capacity	1(mm)	2(mm)
TK-ADG	TK-AD15G	15ml	30.0	70.4
	TK-AD20G	20ml		77.3
	TK-AD30G	30ml		97.4
TK-ADGA	TK-AD15GA	15ml	27.0	86.7
	TK-AD30GA	30ml		121.0
TK-ADB	TK-AD15B	15ml ~ 20ml	27.5	80.6
	TK-AD30B	30ml		110.0
TK-ADBA	TK-AD15BA	15ml	27.0	84.9
	TK-AD30BA	30ml		112.6

Luxury Dropper

MATERIAL

TK-LD

- Teat Silicon / NBR / Elastomer
- Inner Cap PP
- Cap Cover AL
- Pipette Glass
- Bottle Glass
- Bottle Cover AL
- Wiper PE

TK-GD / TK-WD / TK-SD

- Teat Silicon / NBR / Elastomer
- Inner Cap PP
- Cap Cover AL
- Pipette Glass
- Bottle Glass
- Wiper PE

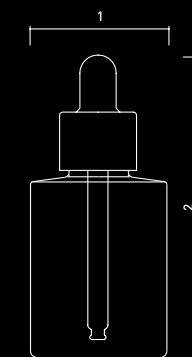
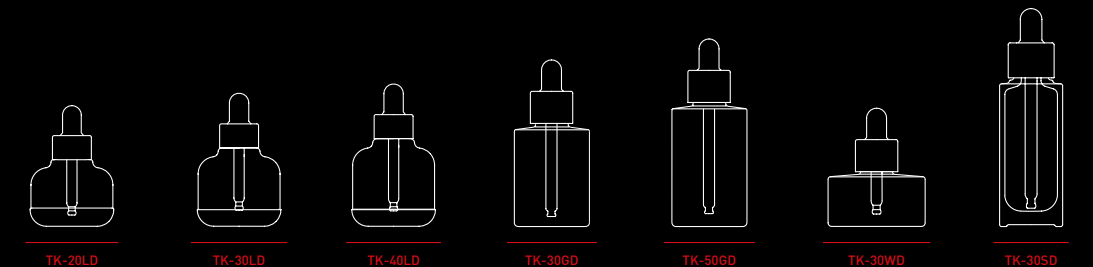

Item.NO	Capacity	1(mm)	2(mm)
TK-20LD	20ml	50.0	75.0
TK-30LD	30ml		80.0
TK-40LD	40ml		85.5
TK-30GD	30ml	40.0	87.4
TK-50GD	50ml	43.0	103.5
TK-30WD	30ml	55.0	67.0
TK-30SD		33.0	114.1

Last Drop Dropper

MATERIAL

TK-PG30LDR / TK-PG30LDS

- Teat Silicon / NBR / Elastomer
- Inner Cap PP
- Cap Cover AL
- Pipette Glass
- Bottle Glass
- Wiper PE

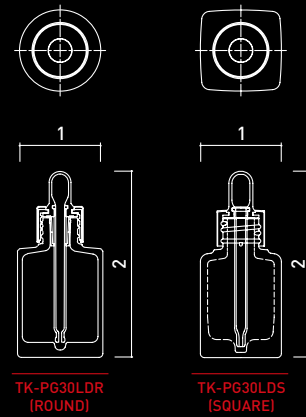

Item.NO	Capacity	1(mm)	2(mm)
TK-PG30LDR	30ml	44.0	94.6
TK-PG30LDS		52.0	92.2

Key Dropper

MATERIAL

TT13HA-3B / TT13HA-A

- Teat Silicon / NBR
- Teat Holder ABS
- Outer Hole Cap ABS
- Inner Hole Cap PP
- Pipette Glass
- Bottle Glass



Item.NO	Capacity	1(mm)	2(mm)
TT13HA-3B	3ml	18.0	60.6
TT13HA-5A	5ml		71.5
TT13HA-7A	7ml	18.3	78.5
TT13HA-10A	10ml		96.5

DB Line

MATERIAL

TK-DB30A

- Outer Cap ABS
- Inner Cap PP
- Actuator ABS
- Pipette Glass
- Bottle Glass
- Bottle Cover ABS
- Bottle Base ABS
- Wiper PE

TK-DB30B

- Outer Cap ABS
- Inner Cap PP
- Actuator ABS
- Pipette Glass
- Bottle Glass
- Bottle Cover ABS
- Bottle Base ABS
- Wiper PE

TK-DB30C

- Outer Cap ABS
- Inner Cap PP
- Actuator ABS
- Rubber Teat Silicon/NBR/Elastomer
- Pipette Glass
- Bottle Glass
- Bottle Cover ABS
- Bottle Base ABS
- Wiper PE

TK-DB30D

- Teat Silicon/NBR/Elastomer
- Cap Cover AL
- Inner Cap PP
- Pipette Glass
- Bottle Glass
- Bottle Cover ABS
- Bottle Base ABS
- Wiper PE

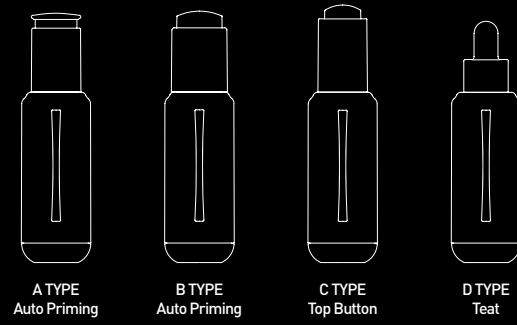
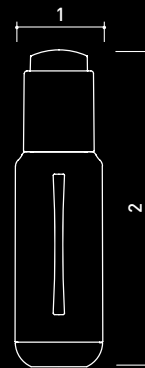

TK-DB30

Item.NO	Capacity	1(mm)	2(mm)
TK-DB30A	30ml	32.7	112.6
TK-DB30B			112.9
TK-DB30C			120.5
TK-DB30D			113.3

IB Line

MATERIAL

TK-IBA

- Outer Cap ABS
- Inner Cap PP
- Button ABS
- Pipette Glass
- Bottle PET
- Wiper PE

TK-IBB

- Outer Cap ABS
- Inner Cap PP
- Button ABS
- Pipette Glass
- Bottle PET
- Wiper PE

TK-IBC

- Outer Cap ABS
- Inner Cap PP
- Button ABS
- Rubber Teat Silicon/NBR/Elastomer
- Pipette Glass
- Bottle PET
- Wiper PE

TK-IBD

- Teat Silicon/NBR/Elastomer
- Cap Cover AL
- Inner Cap PP
- Pipette Glass
- Bottle PET
- Wiper PE

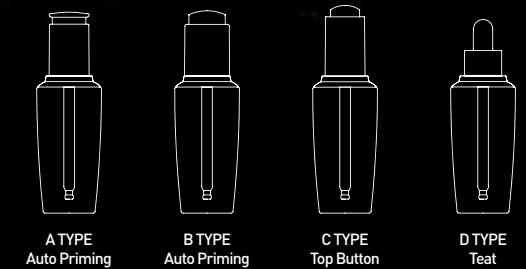
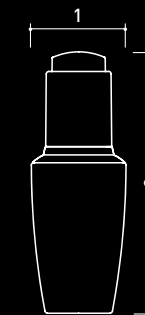

TK-IB30 / TK-IB40

Item.NO	Capacity	1(mm)	2(mm)
TK-IB30A	30ml	37.7	104.0
TK-IB30B			107.0
TK-IB30C			99.0
TK-IB30D			116.5
TK-IB40A	40ml	37.7	117.5
TK-IB40B			120.5
TK-IB40C			112.0
TK-IB40D			112.0

Easy Dropper

MATERIAL

TK-EZ30

- Teat Silicon / NBR / Elastomer
- Outer Cap ABS
- Inner Cap PP
- Pipette Glass
- Inner Bottle PP
- Outer Bottle PETG
- Wiper PE

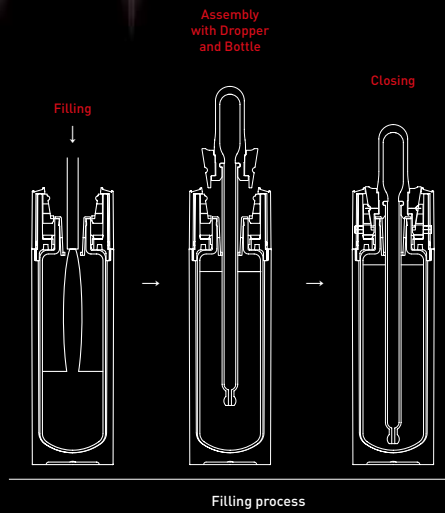
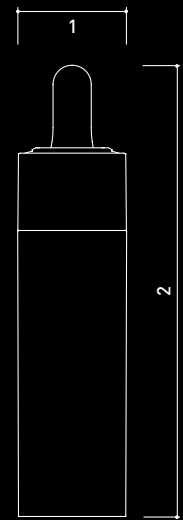

Item.NO	Capacity	1(mm)	2(mm)
TK-EZ30	30ml	32.0	134.8

Dropper for High Viscosity Formula

MATERIAL

HCA-30RD

- Outer Cap ABS
- Inner Cap PP
- Button ABS
- Pipette Glass
- Bottle Glass
- Wiper PE

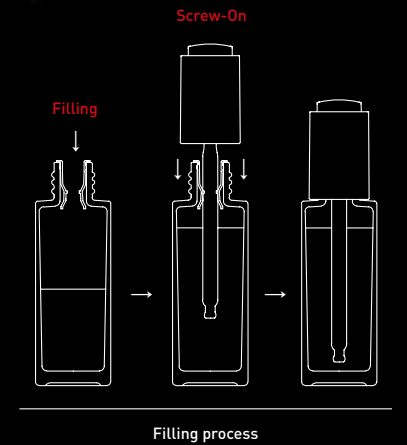

Item.NO	Capacity	1(mm)	2(mm)
HCA-30RD	30ml	31.2	115.7

Dropper 1



MATERIAL

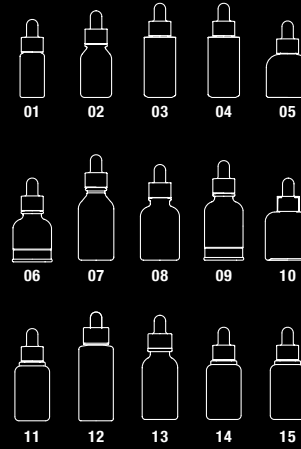

TUBE GLASS BOTTLE

→ Teat	Silicon / NBR / Elastomer
→ Cap Cover	AL
→ Inner Cap	PP
→ Pipette	Glass
→ Bottle	Glass

MOLD GLASS BOTTLE

→ Teat	Silicon / NBR / Elastomer
→ Cap Cover	AL
→ Inner Cap	PP
→ Pipette	Glass
→ Bottle	Glass

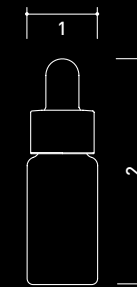

Ref.NO	Item.NO	Capacity	1(mm)	2(mm)
01 TUBE Glass Bottle	SP13HA-3A	3ml	16.4	50.2
	SP13HA-3B		18.0	61.2
	SP13HA-5A		18.0	61.2
	SP13HA-5B	5ml	22.0	55.0
	SP13A-5B		22.0	55.0
	SP13A-7B		22.0	61.0
	SP13HA-7A	7ml	18.0	68.2
	SP18HA-7A		24.0	69.1
	SP20A-7A		24.0	64.5
	SP13A-10B	10ml	22.0	71.0
	SP18HA-10B		24.0	76.7
	SP20A-10A		24.0	75.7
	SP18HA-12B	12ml	26.0	70.5
	SP13A-15B	15ml	22.0	85.0
	SP18HA-15B(26X57)		26.0	80.5
SP18HA-15B(30X47)	30.0		70.0	
SP18HA-30B(30X74)	30ml	30.0	97.0	
02 SP18HA-15RD-FRESH	15ml		85.5	
03 SP18HA-20RD-FRESH	20ml	30.0	108.9	
04 SP18HA-20RD-CYLINDER			102.9	
05 SP18HA-20RD-JESI&ROSI		42.0	75.5	
06 SP18HA-20RD-METAL TRAY	20ml	38.0	84.5	
07 SP18HA-30RD-LOPE		35.0	104.0	
08 SP18HA-30RD-NONI		39.0	94.3	
09 SP18HA-30RD-METAL TRAY	30ml	38.0	101.5	
10 SP18HA-30RD-JESI&ROSI		44.0	91.0	
11 SP18HA-30SQ-SCALA		34.0		
12 SP18HA-30RD-CYLINDER	30ml	35.0	107.5	
13 SP20HA-30RD-COTDE			103.0	
14 SP18HA-50RD-SPAGOA		40.0	115.0	
15 SP20HA-50RD-HILIVING	50ml	40.0	116.0	

MOLD Glass Bottle

Dropper 2



MATERIAL

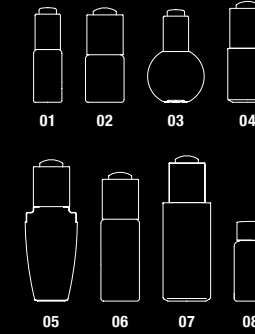

SP13V-B

→ Button	ABS
→ Cap Cover	AL
→ Teat	Silicon / NBR / Elastomer
→ Outer Cap	ABS
→ Inner Cap	PP
→ Pipette	Glass
→ Bottle	Glass

SP18V-B

→ Button	ABS
→ Cap Cover	AL
→ Teat	Silicon / NBR / Elastomer
→ Outer Cap	ABS
→ Inner Cap	PP
→ Pipette	Glass
→ Bottle	Glass

MOLD GLASS

→ Button	ABS
→ Cap Cover	AL
→ Teat	Silicon / NBR / Elastomer
→ Outer Cap	ABS
→ Inner Cap	PP
→ Pipette	Glass
→ Bottle	Glass

CAP SERIES

→ Cap Cover	AL
→ Wad	PE
→ Inner Cap	PP
→ Bottle	Glass

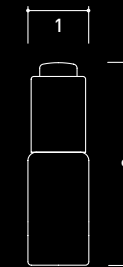

Ref.NO	Item.NO	Capacity	1(mm)	2(mm)	
01 SP13V-B (TUBE Glass)	SP13V-5B	5ml	22.0	59.0	
	SP13V-7B	7ml		64.5	
	SP13V-10B	10ml		75.0	
	SP13V-15B	15ml		89.0	
02 SP18V-B (TUBE Glass)	SP18V-15B	15ml	30.0	73.5	
	SP18V-20B	20ml		82.0	
	SP18V-30B	30ml		98.8	
	03 SP13V-20RD-ZABULANI	20ml		44.0	72.0
MOLD Glass	04 SP18V-15RD	15ml	31.0	78.5	
	04 SP18V-20RD	20ml	30.0	96.0	
	04 SP18V-30RD		31.0	111.8	
	05 SP18V-30RD-METAL SHOULDER	30ml	40.0	110.0	
	06 SP18V-30SQ		36.0	99.9	
	07 SP18V-50RD-006	50ml	40.0	124.5	
	08 CAP SERIES	AP10A-2A	2ml	12.0	51.3
		AP10A-3A			56.3
		AP13HA-3A	3ml	16.4	37.6
		AP13HA-3B		18.0	
AP12A-5A		5ml	15.0	54.2	
AP13HA-5A			18.0	48.6	
AP13HA-5B			22.0	37.6	
AP13HA-7A		7ml	18.0	55.6	
AP13A-7B			22.0	48.0	
AP20A-7A		10ml	24.0	47.0	
AP18HA-10B	24.0		58.5		
AP20A-10A			58.4		
AP18HA-12B	12ml		26.0	52.0	
AP18HA-15B	15ml		62.0		
AP18HA-30B	30ml	35.0	64.5		

Dropper 3



MATERIAL

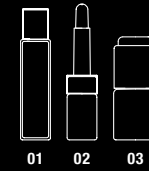

RN11A

- Cap Cover AL
- Inner Cap PP
- Ball Stainless Steel
- Ball Holder PE
- Bottle Glass

TU13HA / TU20A

- Tube Cap PP
- Tube Elastomer
- Cap Cover AL
- Inner Cap PP
- Bottle Glass

DM2 WITH DROPPER

- Button PP
- Cap Cover AL
- Inner Cap PP
- Gasket PE
- Powder Bag LDPE
- Bottle Glass

- Dropper
- Teat Silicon / NBR / Elastomer
- Cap Cover AL
- Inner Cap PP
- Pipette Glass

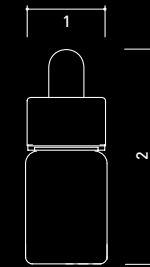

Ref.NO	Item.NO	Capacity	1(mm)	2(mm)
01 RN11A	RN11A-5A	5ml	15.0	66.0
	RN11A-8A	8ml		84.0
	RN11A-10A	10ml		107.0
02 TU13HA	TU13HA-3B	3ml	18.0	76.0
	TU13HA-5A	5ml		86.9
	TU13HA-5B	5ml		22.0
02 TU20A	TU13HA-7A	7ml	18.0	94.4
	TU20A-7A	7ml		91.5
	TU20A-10A	10ml		24.0
03 DM2	DM2-7A	7ml	26.0	59.9
	DM2-10A	10ml		71.4
	DM2-15A	15ml		77.9

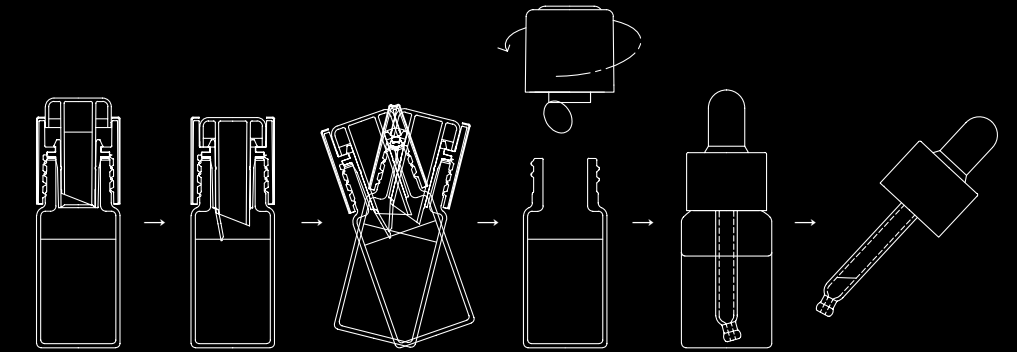

HOW TO USE (DM2)

Tube with Cap



Shape	Tube Diameter	Tube Length(mm)		Orifice(mm)	Material		
		Min	Max				
ROUND	ø16	45.0	100.0	1.0-1.5	5 Layers		
	ø19						
	ø22						
	ø25			150.0		1.5-3.0	
	ø30						
	ø35					170.0	1.5-6.0
	ø40						
	ø43						
	ø45			190.0		1.5-7.0	5 Layers / 7 Layers
	ø47						
ø50							
ø55							
OVAL	ø22	185.0	180.0	1.5-3.0			
	ø25						
	ø35			1.5-6.0			
	ø40						
	ø43						
	ø45			1.5-7.0			
	ø47						
ø50							

TOLY

Contacts

Malta
France
U.K.
Belgium
Italy
Hong Kong
U.S.A.
China
Korea

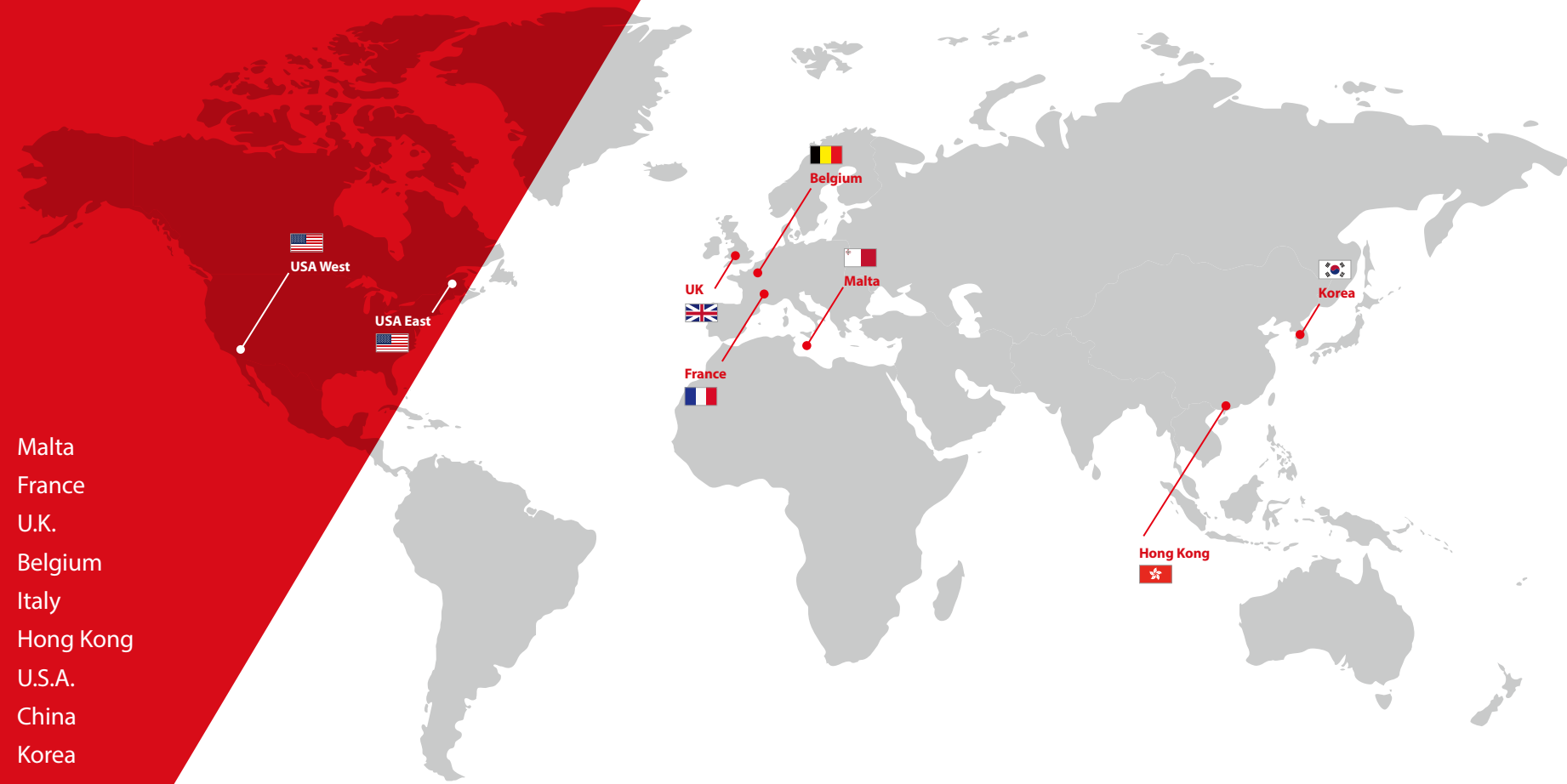

MALTA

Toly Corporate Offices and Innovation Centre
BLB 036A, Bulebel Industrial Estate,
Zejtun, ZTN 3000
Malta
Tel +356-2169-3520
Fax +356-2169-3540

Toly Malta Factory
BLB 006, Bulebel Industrial Estate,
Zejtun, ZTN 3000
Malta
Tel +356-2366-0400
Fax +356-2169-3540

EUROPE

Toly France
120, Avenue des Champs Elysees,
Batiment B, 75008,
Paris, France
Tel +33-1-5376-4222

Toly Belgium
Rue Granbonpre 11,
Batiment E,
B-1348 Louvain-la-Neuve,
Belgium
Tel +32-1045-7547
Fax +32-1045-1571

HONG KONG

Toly Asia Ltd.
Suite 2308, 23/F APEC plaza,
49 Hoi Yuen Road, Kwun Tong,
Kowloon,
Hong Kong
Tel +852-3421-1248
Fax +852-3421-1255

U.K.

Toly Products (UK)Ltd.
9, Station Road,
Marlow, Bucks, SL7 1NG
United Kingdom
Tel +44-16-2849-8800
Fax +44-16-2848-6910

USA

Toly USA Inc.
264W. 40th Street, 17th Floor,
New York, NY 10018
USA
Tel +1-646-434-8872

**Toly USA
West Coast Office**
3878 W. Carson Street, Suite 218,
Torrance, CA 90503
USA
Tel +1-310-694-3083
Fax +1-310-684-2639

CHINA

Toly China Ltd.
Pangushi industrial district,
kengzi, ShenShan High way,
Long Gang, Shenzhen,
China
Tel +86-755-8411-3985
Fax +86-755-8411-3944

KOREA

Toly Korea Inc.
27, Buheung-ro 315,
Wonmi-gu, Bucheon, Gyeonggi-Do,
Korea
Tel +82-32-326-0222
Fax +82-32-326-0228

Toly Korea Manufacturing
60, Oksan-ro 213 beon-gil,
Bucheon, Gyeonggi-do, Korea
Tel +82-32-679-8222
Fax +82-32-676-2555